

CORROLINE+

Smoothbore Flexible PTFE Hose



CHEMICAL RESISTANT

KINK RESISTANT

SELF CLEANING

FLEXIBLE

HYGIENIC

Contents

INTRODUCTION TO CORROLINE⁺

- PTFE - The Optimum Choice For Hose Linings **Page 3**
- Corroline⁺ - The New Product Design from Aflex Hose **Page 4**
- Corroline⁺ Hose Description **Page 5**
- Corroline⁺ Specifications Properties **Page 6**
- Comparison with Competitors Hose **Page 7**
- How to Order Corroline⁺ Hose Assemblies **Page 8**
- Corroline⁺ EN 16643 Hose Assembly Electrical Property Grades **Page 9**
- Corroline⁺ Part Number System **Page 10**

HOSE

- Corroline⁺ Hose Liners **Page 11**
- Corroline⁺ External Protection Systems **Page 12**

FLANGE FITTINGS

- Swivel Flange Fittings, Non-Lined **Page 13**
- Flange Fittings, PTFE Lined and Step-Up Adaptors **Page 14**

CAM AND GROOVE FITTINGS (CAMLOCKS)

- Female Cam & Groove Fittings, PTFE Lined and Non Lined **Page 15**
- Male Cam & Groove Fittings, PTFE Lined and Non Lined and Cam Male-to-Flange Adaptors, PTFE Lined **Page 16**

SANITARY (TRICLOVER) FITTINGS

- Sanitary and Mini-Sanitary Triclover Fittings **Page 17**
- 90° Elbow Sanitary Triclover Fittings **Page 18**

HYGIENIC FITTINGS (EUROPEAN)

- DIN 11851 Male and Female Fittings **Page 19**

JIC FITTINGS

- 37° JIC Female Fittings & NPT Male & Female Unions **Page 20**

NPT & BSPT FITTINGS and TUBE FITTINGS

- NPT & BSPT Fixed Male Fittings and NPT Fixed Female Fittings **Page 21**
- BSP 60° Cone Seat Female Unions and Non-Lined Tube Adapter (Grooved Standpipe) Fittings **Page 22**

DIP PIPES

Page 23

CORROLINE⁺ LABELLING & COLOUR CODING

Page 24

CORROLINE⁺ SPECIAL USAGE CONDITIONS

Page 25

QUALITY ASSURANCE, CERTIFICATION & APPROVALS

Page 26

CORRECT HOSE CONFIGURATION & LENGTH CALCULATIONS

- for Bend Radius **Page 27**
- for Abrasion & Torque **Page 28**
- for Length Calculation **Page 29**

CONDITIONS OF SALE

Pages 30 & 31

PTFE - The Optimum Choice For Hose Linings

Section from a PTFE Molecule, 16 Angstrom Units long

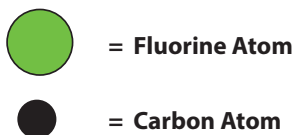
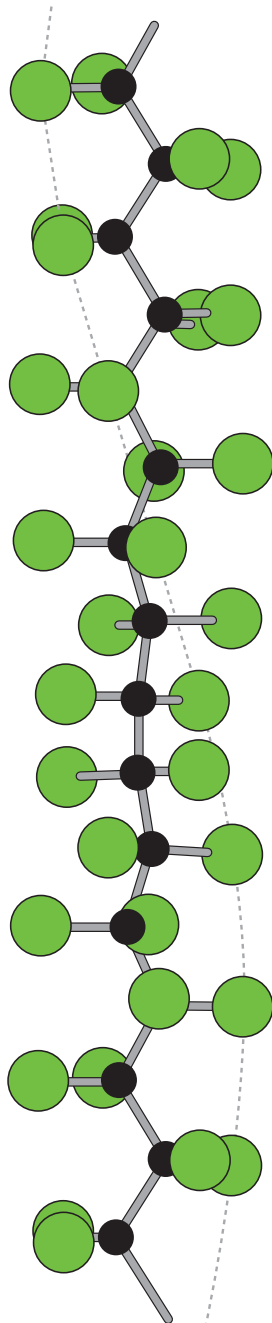

PTFE, or Polytetrafluoroethylene, comprises of long-chain molecules of carbon atoms, each linked to two fluorine atoms.

The fluorine atoms provide a helical spiral which surrounds the carbon chain and protects it.

It is this structure which creates the unique properties for which PTFE is well-known.

- **Excellent Chemical Resistance**

PTFE is renowned as the most chemically resistant material known. Only a very few, very unusual substances and conditions can affect it, like Fluorine gas at high temperature and pressure and liquid, boiling sodium metal.

PTFE lined hoses can therefore be used for a wider variety of chemicals than any other hose type, making it the ideal choice for very corrosive chemical applications and multi-product applications.

- **Non-Stick Surface**

The use of PTFE as a surface for cookware products has demonstrated to the world how easily cleanable PTFE surfaces are.

This means that PTFE lined hoses can be purged 100% clean more quickly, easily and reliably than any other type of hose.

- **Excellent Temperature Range**

The cookware application also demonstrates another of PTFE's many attributes - temperature resistance. PTFE itself can be used as a hose liner at temperatures from -150°C up to $+260^{\circ}\text{C}$, dependent upon the hose design and the application conditions.

This is the widest temperature range of any rubber or plastic hose lining material.

- **Very High Electrical Resistance**

Most aerospace electrical wiring has a PTFE cover, due to the excellent electrical resistance of PTFE. This property is however, a disadvantage in some hose applications where there is a risk of developing an electrostatic charge inside the hose bore. Aflex Hose have developed a non-contaminant, FDA and USP Class VI compliant solution to this problem.

- **Hose Design**

The only issue with PTFE as a hose lining material is the best way it can be integrated in to the hose design. This is where Aflex Hose have a proven record of success over the last 40 years.

Corroline⁺ - The New Product Design from Aflex Hose

**CORROLINE⁺ GP HOSE, FITTED WITH
A NON-LINED FLANGE FITTING**

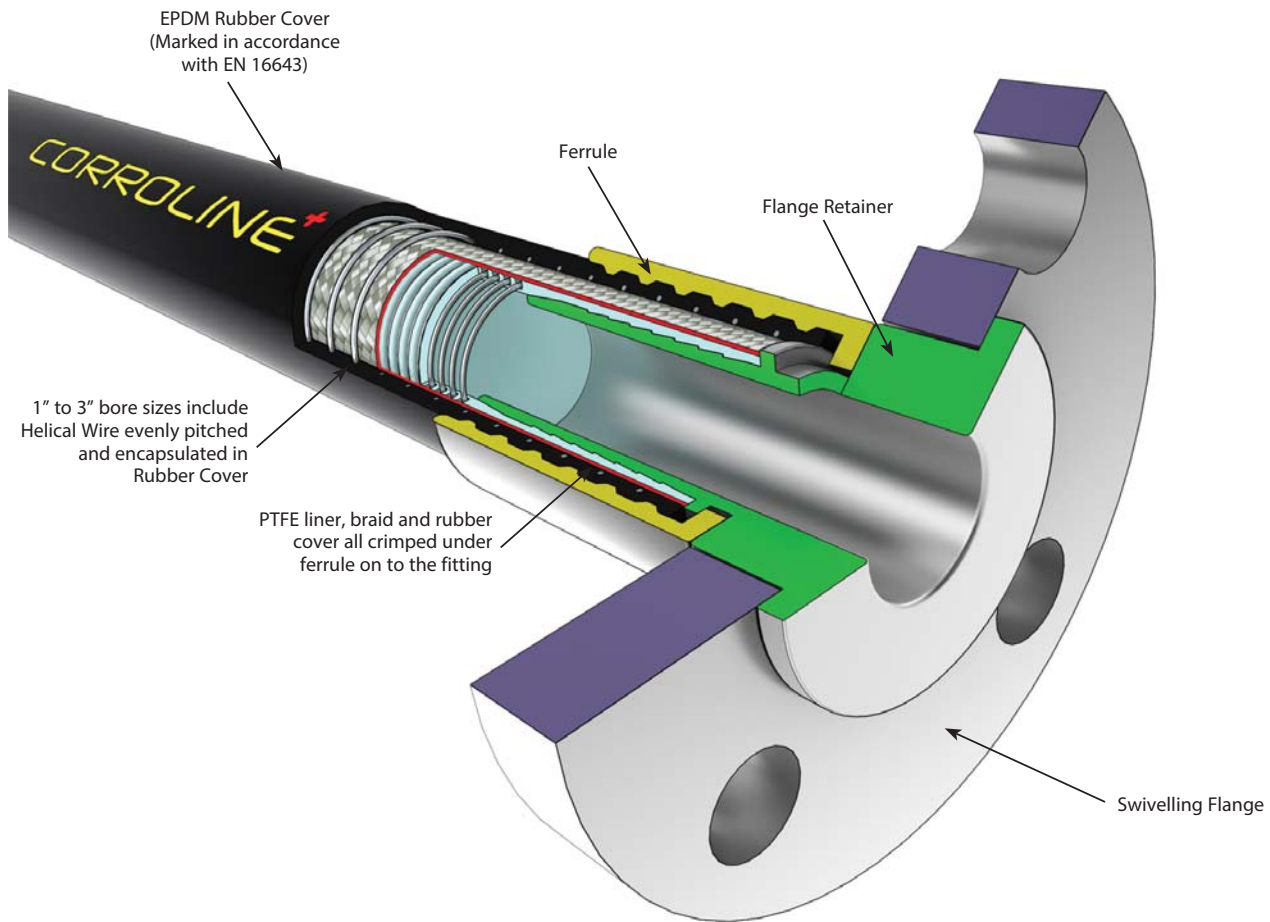

Corroline⁺ Hose

Corroline hose was developed and introduced by Aflex Hose in 2008, specifically to provide customers with a new smooth bore PTFE lined hose which had better flexibility than other chemical hose products which were available.

More recently customers have asked whether Aflex could improve their product further still by improving the kink resistance, while retaining the excellent flexibility.

In response to our customer's requests Aflex Hose have introduced a new version of Corroline, which combines excellent flexibility with exceptional kink resistance, named - CORROLINE⁺.

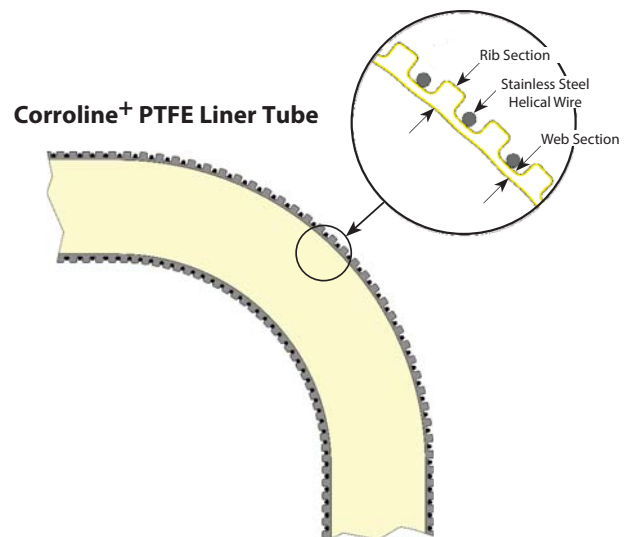

Corroline⁺ Hose Description

CORROLINE⁺ GP HOSE, FITTED WITH AN INTEGRAL PTFE LINED FLANGE FITTING

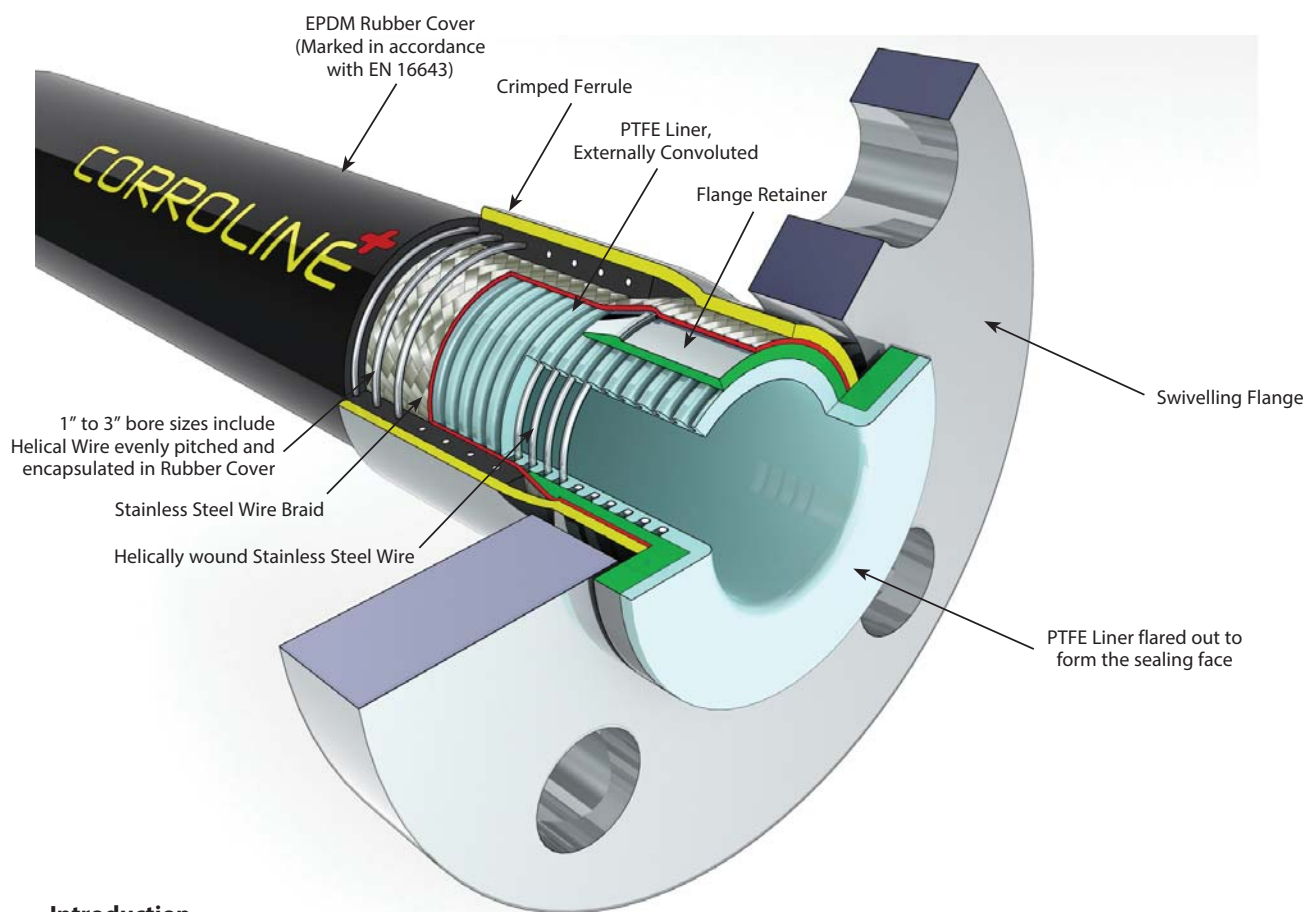

Introduction

Corroline⁺ hose was designed and developed to provide customers with a universal chemical hose product which combined all the requirements they had requested for chemical plant applications, particularly the need for improved flexibility and kink resistance.

Corroline⁺ hose provides a superior alternative to the wide variety of alternative Chemical Hose products currently available.

Construction

Corroline⁺ is built around a unique PTFE hose liner design, which has a slightly rippled smooth bore inside, but convoluted outside to generate excellent flexibility combined with "hoop strength". Grade GP hose has a natural (clear) PTFE liner tube and Grade AS hose has an antistatic (Black) PTFE liner tube.

A stainless helical wire is wound in to the external convolutions, which adds to the kink resistance, crush resistance and the resistance of the hose to both pressure and vacuum.

This reinforced PTFE Liner construction is strong enough to withstand vacuum to -0.9bar and kinking without the need for either internal convolutions or the need to bond the liner to an outer cover, making it an ideal hose liner design, and a significant improvement upon standard products currently available.

The PTFE liner is then further reinforced with a 304 SS wire braid. A smooth finish black antistatic EPDM rubber cover is extruded over the braid, which includes a helical reinforcement wire encapsulated in the rubber cover which renders the hose kinkproof. The rubber cover has a mirror smooth surface finish to aid cleaning, and the antistatic rubber is specially compounded to make the hose 'fireproof'.

Corroline⁺ Hose - The best Flexible Hose for Chemical Plant Applications.

Corroline⁺ Specifications & Properties

Specifications for Corroline⁺ Hose Grades

Nominal Hose Size		Actual Bore Size		Outside Diameter		Maximum Working Pressure		Minimum Bend Radius		**Maximum Continuous Lengths		Weight per Unit Length	
in	mm	in	mm	in	mm	psi	bar	in	mm	ft	mtrs	Kg/Mtr	lb/ft
1/2 *	13	0.51	13.0	0.85	21.5	1000	69	1 3/8	38	100	30	0.40	0.27
3/4 *	20	0.76	19.4	1.12	28.5	624	43	2	50	100	30	0.70	0.47
1	25	1.01	25.7	1.45	37.0	600	41	2 3/4	70	100	30	1.10	0.74
1 1/4	32	1.26	32.0	1.75	44.6	550	38	3 5/16	100	100	30	1.60	1.07
1 1/2	40	1.51	38.5	2.03	51.7	500	34	4 3/4	120	100	30	1.92	1.29
2	50	2.00	51.0	2.55	65.0	400	28	5 15/16	150	100	30	2.80	1.88
2 1/2	65	2.51	63.7	3.17	80.5	290	20	11 13/16	300	59	18	4.18	2.80
3	80	3.02	76.8	3.65	92.8	218	15	13 3/4	350	49	15	5.05	3.38

* The 1/2" and 3/4" size hoses do not include the helical wire embedded in the rubber

** Longer lengths may be available, to special order

- **Pressure and Temperature Limitations**

Maximum Working Pressures - as listed above apply from -40°C (-40°F) up to the maximum operating temperature of 150°C (302°F).

Burst Pressures - The hose burst pressures are equal to or more than the maximum working pressures × 4.

- **Vacuum Limitations**

Usable at vacuum to -0.9bar up to 150°C/302°F.

- **Flexibility**

Much less force to bend than any other smooth bore PTFE lined hose product.

- **Kinkproof**

Much more resistant to kinking than any other smooth bore PTFE lined hose product, and much more kink resistant than the previous Corroline product.

- **Fire resistance**

Corroline⁺ hose is Fireproof to BS5173 Section 103.13 Parts 6.2 and 6.3, and Corroline⁺ hose assemblies can be upgraded to Fireproof by applying DBK 300 at each end (see pg 12). All assemblies comply with the flammability requirement as set out in EN 16643.

- **'Rolling U' Flex Life Test**

More than 100 × the flex life to failure compared with all other types of smooth bore PTFE, FEP and PFA lined rubber covered hose products.

- **Flow rates**

More than 2 times the flow rates for convoluted bore hose designs. Consult Aflex Hose for specific flow rate information.

- **Gas permeability**

Reduced gas permeability compared with other PTFE lined hose designs, due to the heavy compression applied to the PTFE during processing, which reduces porosity.

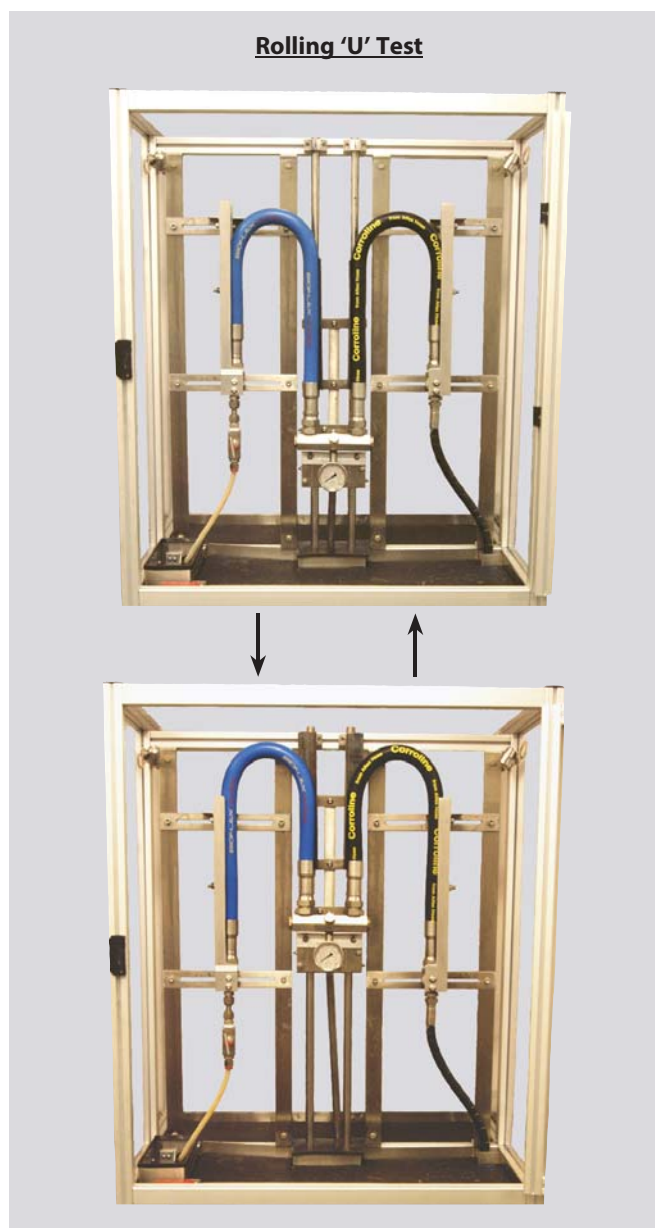

Comparison with Competitors Hose

Competitors PTFE, FEP, PFA or another Plastic or Fluoroplastic thin wall hose liner bonded inside a Rubber Hose.

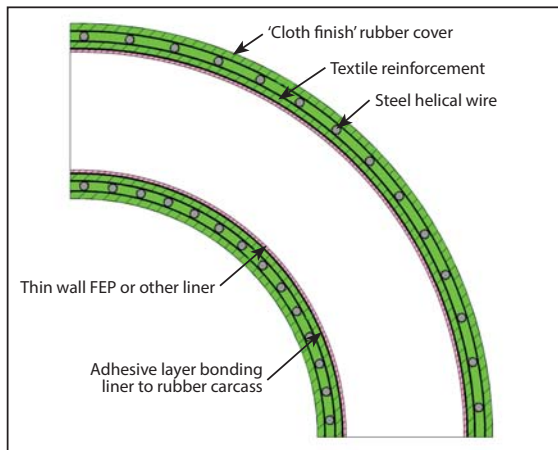

Corroline⁺ PTFE lined hose, Stainless Steel wire helix and braid, outer rubber cover.

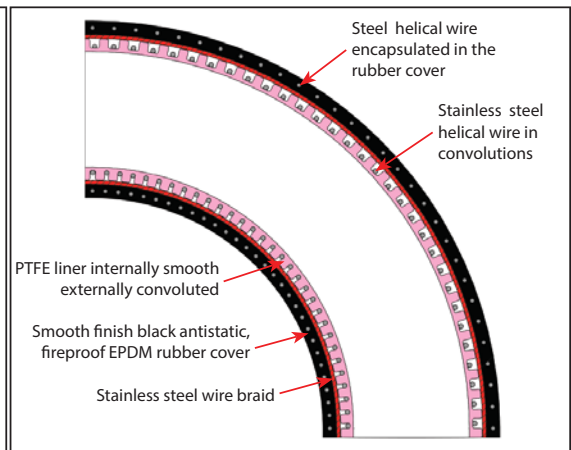

Bore Profile	Smoothbore, but internal profile collapses into large uneven ripples when flexed	✗	Smoothbore internal profile slightly rippled, ripples increase evenly when flexed	✓
Liner Material	FEP or another Fluoroplastic liner, - Good but not as good as PTFE XLPE or UHMWPE - Fair chemical resistance	✗ X	PTFE Liner -Best for chemical resistance and temperature resistance	✓
Process Fluid Contamination Risk	High Risk - adhesive layer can leach in to contaminate the process fluid through pinholes in the thin wall liner, caused by static discharge, flex induced porosity, hose kinking etc.	X	No Risk - no adhesive layer - no non-FDA approved materials present in the hose construction	✓
Flexibility	Fair to Poor - Very stiff, with a large minimum bend radius	X	Good - More flexible, reduced minimum bend radius	✓
Flex Life (Rolling 'U' Test)	Poor, typically from 1000 to 7000 cycles to failure	X	Excellent 100,000+ cycles without failure	✓
Kink Resistance	Good	✗	Excellent	✓
Cut Through or Puncture Resistance	Fair (Textile braid protection)	✗	Good (Stainless Steel Wire Braid Protection)	✓
Antistatic Liner Quality to FDA Requirements (<2.5% High Purity Black)	Often more than 2.5% Black (non-FDA), often unevenly dispersed, leading to carbon agglomerates which contaminate Process Fluid	X	Always less than 2.5% Black, very evenly dispersed and guaranteed agglomerate-free. 'Leachable and Extractable' testing yields zero carbon	✓
Fire Resistance	Not tested or approved to be Fireproof	X	Tested and approved 'Fireproof' to BS5173 Section 103.13	✓

How to Order Corroline⁺ Hose Assemblies

Corroline Hose Assemblies

Corroline⁺ hose is custom built into hose assemblies after the hose size and grade, length and end fittings have been selected.

The specification and information contained in this brochure can be used to make these selections, but if there are any doubts concerning the hose usage limitations or performance capabilities, customers should request expert advice from Aflex Hose.

Selecting the Hose Grade

There are two types of PTFE hose liner tube available, natural (GP) grade and antistatic black (AS) grade, fully described on page 11

If needed there are 3 options for extra protection of the hose against externally applied abrasion and mechanical damage, fully described on page 12:

- Double Rubber Cover end protection cuffs (DBK)
- Safeguard HDPE spiral-wrap for abrasion protection (SG)
- Helically wound, heavy gauge SS wire outer Protection Coil (PC)

Selecting the Hose Assembly Length

The lengths of Corroline⁺ hose assemblies are as specified by the customer and the length is measured from the sealing face at one end fitting to the same at the other end of the hose.

Length tolerances are normally -0% +2%.

Maximum lengths are given under Specifications on page 6

Minimum lengths can be calculated from the configuration data on pages 27 - 29.

Selecting the End Fittings

The range of non-lined standard PTFE tail end fittings and materials are given on pages 13 - 23

Flange fittings and Cam and Groove fittings are available either non-lined, or with integral PTFE lined and flared ends, see pages 14-16

Stainless Steel End Fitting Materials

Non-Lined Spigots - are all made from Grade 316L SS

PTFE Lined Spigots - are all made from Grade 316L or Grade 316C SS

Cam and Groove Female Fittings - are made from Grade 316C SS (Body) and 316L SS (Spigot)

Swivelling Nuts and Flanges - are all made from Grade 304 SS

Ferrules - most ferrules are made from Grade 304 SS, except some which are made from Grade 316L SS. Consult Aflex Hose if necessary.

The equivalent specification for the different Grades of Stainless Steel are listed below:

Specification Equivalent List

Grade	BS - British Standards	AISI - American Standard or C = Casting Grade	EN - European Norm
316L SS	BS 316 S11	AISI 316 L	EN 1.4404
316C SS	BS 316 C16	CF8M	EN 1.4408
304 SS	BS 304 S15	AISI 304	EN 1.4301

**To special order, end fittings components can be made in non-standard grades of SS such as 1.4571, 1.4435, or other materials such as Hastelloy or Monel*

How to Order

The quantity, hose size, grade, length and fittings must be specified in full.

Either by a full, written description. The hose grade can be specified by the code initials e.g. 'Corroline⁺ AS, SG' defines an antistatic PTFE lined hose which includes an outer Safeguard sleeve.

The quantity, length and fittings can then be written in - e.g. "4 off x 1" bore Corroline⁺ AS, SG hose x 3.00 metres long. Both ends non-lined ANSI 150# S/S Flanges".

Or by Part Numbers, as defined on page 10 - e.g. 4 off Part No. 16-CLN+AS-SG-3.00m-12-12

Any special requirements relating to the hose construction, or information required on Tags, or Certificates, or special testing requirements, must be specified in full on the enquiry or purchase order.

Conditions of Sale

Corroline⁺ hose and hose assemblies are only supplied on the basis that the customer has read and accepted the Conditions of Sale as given on pg's 30 & 31. Customers own Conditions of Sale (or equivalent) are not accepted unless an acceptance signed by a Director of Aflex is supplied.

Corroline⁺

EN 16643 Hose Assembly Electrical Property Grades

The hose assembly electrical property grades and electrical resistance limits are defined within EN 16643 and tested in accordance with BS EN ISO 8031. Aflex Hose electrically conductive (**EC**) assemblies are defined in EN 16643 as *electrically bonded* and given the symbol **M**. M-grade assemblies exhibit a maximum electrical resistance of 100Ω between end fittings. Aflex Hose anti-static (**AS**) PTFE liners and rubber covers are termed *static dissipative* within EN 16643 and given the symbol **Ω** followed by letters that specify either the liner, cover or both; **L**=liner, **C**=cover, **CL**= cover & liner. Ω-grade covers or liners exhibit an electrical resistance of 10³-10⁸Ω.

The table below identifies each EN 16643 electrical grade for a hose assembly along with a brief description and example assembly configuration.

EN16643 Electrical Grade For Hose Assembly	EN16643 Description	Example Hose Assembly
Grade M	Electrically bonded without static-dissipative lining or cover	Not available
M/Ω-L	Electrically bonded and static-dissipative lining	Not available
M/Ω-C	Electrically bonded and static-dissipative cover	CLN+ Ends ASA150 Lined
M/Ω-CL	Electrically bonded and static-dissipative cover and lining	CLN+AS Ends ASA150 Lined
I	Electrically insulated (no electrical bonding AND no static-dissipative layers)	Not available
Ω-L	Static dissipative lining without electrical bonding	Not available
Ω-C	Static dissipative cover without electrical bonding	CLN+ Ends ASA150 PP spigot and flange (special order)
Ω-CL	Static dissipative cover and lining without electrical bonding	CLN+AS Ends ASA150 PP spigot and flange (special order)

Part Numbers for Corroline⁺ Hose Assemblies

If required, Corroline⁺ Hose Assemblies can be defined by an individual Part Number, made up of **5** entries as below:

1

Hose Size	Size Part No.
1/2"	08
3/4"	12
1"	16
1 1/4"	20
1 1/2"	24
2"	32
2 1/2"	40
3"	48

2

Hose Type	Type Part No.
Corroline ⁺ GP (Natural PTFE Liner)	CLN+
Corroline ⁺ AS (Antistatic PTFE Liner)	CLN+AS

3

External Protection	Type Part No.
Double Rubber Cover	DBK
Safeguard HDPE Sleeve	SG
S/S Wire Protection Coil	PC

4

Length
The overall hose length between the sealing faces at each end is given as the Length Part No either in decimal Metres followed by 'm' or inches followed by 'in'

5
&
6

Assembled End Fitting Description * All Components in Stainless Steel N/L = Not PTFE Lined, PTFE/L = PTFE Lined and Flared	End Fitting Part No.
N/L JIC Female	02
N/L Fixed Male Pipe, NPT Thread	03
N/L Fixed Female Pipe, NPT Thread	06
N/L JIC-to-NPT Male Union	08
N/L JIC-to-Female Union	08F
N/L Straight Sanitary Tri Clamp, 50.5mm, 1.984" Diameter	-
22mm, 0.870" Exit Diameter (Standard)	10
34.9mm, 1.370" Exit Diameter (Set Up)	10/S
N/L Straight Mini Sanitary Tri Clamp, 0.984" Diameter	-
0.370" Exit Diameter (Standard)	11
0.625" Exit Diameter (Step-Up)	11/S
N/L *ANSI 150# Swivelling Flange	12
PTFE/L *ANSI 150# Swivelling Flange	12L
N/L Cam and Groove, Locking Arm Swivelling Female	16
PTFE/L Cam and Groove, Locking Arm Female	16L
N/L Cam and Groove Male	17
PTFE/L Cam and Groove, Male	17L
N/L DIN 11851 Female	23
PTFE/L DIN 11851 Female	23L

Notes - For Flange only: Add '/ZP' for Carbon Steel Zinc Plated

Elbows: Add '/90°' for Non-Lined 90° elbows or, add '/90° L' for PTFE Lined 90° elbows

Additional Requirements:

- Any additional requirements which are not included in the Part Number must be written out in full in the Order, including any special labelling or colour coding.

- When purchasing Triclovers/Sanitary Fittings please specify the surface finish required.

Example:

A 3/4" bore Corroline⁺ Hose Assembly with an Antistatic PTFE Liner and an outer Safeguard Sleeve with:

End (1) - a 3/4" ANSI 150# Swivel Flange, PTFE Lined

End (2) - a Cam and Groove Swivelling Female, PTFE Lined

and a Length of - 2.35 metres

Hose Assembly Part No. = 12 - CLN+AS - SG - 2.35m - 12L - 16L

Entry No.	1	2	3	4	5	6
-----------	----------	----------	----------	----------	----------	----------

Corroline⁺ Hose Liners

GP - General Purpose Liner



Purpose

Corroline⁺ GP is the 'General Purpose' grade, for use in all applications where fluids or gases are being conveyed which do not generate a risk of static charge development (see 'AS').

Materials & Specifications

Corroline⁺ GP is a virgin PTFE liner, manufactured from hose grade PTFE which conforms to the requirements of: FDA 21 CFR 177.1550.

The helical reinforcement in the convolutions in the liner is High Tensile Grade 316 SS wire. The helical reinforcing wire embedded in the rubber cover is carbon steel. The specially compounded, black EPDM rubber cover is antistatic in accordance with EN ISO 8031 Annex A and the stainless steel braid is grade 304 SS.

GP & AS grade approvals

The full list of approvals and certifications are given on page 26.

FIREPROOF



Corroline⁺ GP and AS grade hose is Fireproof to BS5173 Section 103.13 Part 6.2 and 6.3. When end fittings are assembled to the hose, the assembly is Fire Resistant, but can be made Fireproof by adding DBK-300 rubber cover end protection. Corroline⁺ meets the requirements of German safety regulation TRbF 131/2 and EN16643 flame resistance.

SPECIAL NOTE:

Electrical Continuity (Also known as 'Electrically Bonded')

Electrical continuity requires that the hose assembly supplied is electrically continuous, or conductive, between metal end fittings at each end of the hose. This can apply whether the hose is GP or AS grade.

The requirements for this are specified in the German Document BRG 132 and EN 16643, when tested in accordance with EN ISO 8031, which requires that the resistance between end fittings shall be $<10^2$ Ohms per assembly. For hose assemblies which meet this requirement a Grade 'M' marking is applied in accordance with EN 16643.

Corroline⁺ Hose Assemblies are all electrically continuous with a resistance of less than 100 ohms.

AS - Anti-Static PTFE Liner



Purpose

Corroline⁺ AS is an essential requirement in applications where there is the risk of an electrostatic charge build-up on the inside surface of the PTFE tube which may then discharge through the tube wall. Media passing through which create such a risk are fluids which have a Conductance of less than 10^{-8} S/m (Siemens per Metre), or 10^4 pS/m such as fuels, solvents, freons, some WFI (ultra-pure 'Water for Injection') and non-polar organics which are being transferred at a medium to high flow velocity.

All twin or multi phase media, and any non-mixing media, such as powder in air, or water droplets in steam, in gases or in oil, also colloidal fluids constitute a particular hazard for static charge generation, and always require grade AS.

If in doubt, consult Aflex Hose.

Materials & Specifications

Corroline⁺ AS is an anti-static PTFE liner manufactured from FDA 21 CFR 177.1550 approved PTFE, and less than 2.5% of 'high purity' Carbon Black material to FDA requirement 21 CFR 178.3297 and European Commission Directive 2007/19/EC. The carbon is encapsulated by the PTFE, and in normal, non-abrasive applications will not come loose to contaminate any fluid passing through. This has been proved during Leachables and Extractables testing.

Antistatic Hose Assemblies

When 'AS' (Antistatic) grade hose is specified, then the hose or hose assembly supplied will be tested in accordance with EN ISO 8031 and meet the Antistatic requirements of EN16643. This requires, for an antistatic liner or antistatic cover, that the resistance between an appropriately placed foam electrode and a metallic end fitting will be between 10^3 to 10^8 Ohms per assembly. For hose assemblies which meet these requirements an appropriate Grade 'Ω' marking is applied in accordance with EN 16643.

NOTE: When in service, at least one end fitting must be connected to earth, to permit dissipation of the static charge from the end fitting.

Corroline⁺ External Protection Systems

SG - Safeguard Protections Sleeve



Purpose

To protect the hose from excessive external abrasion and mechanical damage in rough applications..

Design

A lightweight black HDPE (High Density Poly Ethylene) 'Safeguard' strip is spirally wound along the hose and secured by crimping at each end.

Limitations

Temperature Range -40°C (-40°F) up to 110°C (230°F).

Internal fluid temperatures up to +140°C (284°F) are acceptable, when external temperatures are ambient.

The minimum hose assembly length must be doubled if Safeguard is being used, and the maximum assembly lengths for all sizes are capped at 20 metres (65 feet).

Safeguard is available with anti-static properties and complies with the requirements of a static-dissipative cover within EN 16643 (see page 9 for further information). Request details upon enquiry.

PC - Protection Coil



Purpose

To protect the hose from excessive external abrasion and mechanical damage in rough applications without the temperature limitations which apply to the Safeguard sleeve.

Design

A large diameter stainless steel wire is spirally wrapped on to the rubber cover, and welded to the ferrule at each end.

Maximum assembly lengths for all sizes are capped at 20 metres (65 feet)

DBK 300 - Double Rubber Cover End Protection



Purpose

In applications where the hose assembly may be mechanically abused by pulling the hose with excessive force at an angle to a connected end fitting. Also to render a hose assembly 'Fireproof' by protecting the end fitting area against the effects of fire.

Design

A second layer of rubber is applied and vulcanised directly on to the hose and the end fitting ferrule, 12" (300mm) along the hose from the fitting.

Corroline⁺ Non-Lined Swivel Flange Fittings

End Fitting Specifications

- ANSI B16.5 (also ASME B16.5) Class 150# and 300#
- DIN PN10, PN16 and PN40*
- JIS 10K
- Other Pressure Ratings and Flange Specifications are also available.

*DIN PN10, PN16 and PN40 Flanges all have the same dimensions, and so are fully interchangeable

Temperature and Pressure Ratings

- ANSI 150# = 16 Bar (230 psi), ANSI 300# = 41.4 Bar (600 psi)
- DIN PN10 = 10 Bar (145 psi), DIN PN16 = 16 Bar (230 psi)
- DIN PN40 = 40 Bar (580 psi)

End Fitting Materials

- Flanges normally in Grade 304 SS, or Grade 316 SS if required
- Flange Retainers in Grade 316L SS
- Ferrules, most in Grade 304 SS, some sizes in Grade 316 SS

Alternative Options for Flange Component only:

- Zinc Plated Carbon Steel
- Grade 316 SS

Surface Finish :

- All surface finishes are to ASME BPE-SF-O (No finish required).
- If a specified finish on a particular surface is required, please state on the enquiry and order.

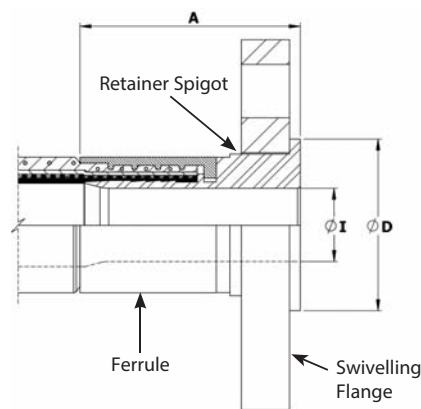

Nominal Hose Size		Fitting Length A ASA150		Flared Diameter D ASA150		Fitting Inside Diameter I ASA150		Weight of Fitting	
in	mm	in	mm	in	mm	in	mm	Kg	Lbs
1/2	13	1.67	42.50	1.38	35.00	0.37	9.40	0.57	1.25
3/4	20	1.86	47.24	1.69	42.90	0.62	15.75	0.84	1.84
1	25	2.36	60.00	2.00	50.80	0.85	21.50	1.20	2.63
1 1/4	32	2.67	67.72	2.50	63.50	1.03	26.21	1.59	3.50
1 1/2	40	2.75	69.86	2.87	73.00	1.25	31.75	2.15	4.73
2	50	3.20	81.22	3.62	92.00	1.76	44.60	2.92	6.41
2 1/2	65	3.70	94.00	4.13	105.00	2.25	57.15	4.36	9.59
3	80	3.74	95.00	5.00	127.00	2.63	66.7	6.02	13.24

Nominal Hose Size		Fitting Length A PN10/16		Flared Diameter D PN10/16		Fitting Inside Diameter I PN10/16		Weight of Fitting	
in	mm	in	mm	in	mm	in	mm	Kg	Lbs
1/2	13	1.79	45.50	1.77	45.00	0.37	9.40	0.78	1.72
3/4	20	2.11	53.50	2.28	58.00	0.62	15.75	1.12	2.47
1	25	2.44	62.00	2.68	68.00	1.12	28.50	1.43	3.15
1 1/4	32	2.70	68.50	3.07	78.00	1.03	26.21	2.35	5.17
1 1/2	40	2.91	74.00	3.49	88.00	1.70	43.10	2.76	6.06
2	50	3.50	89.00	4.02	102.00	2.15	54.50	3.62	7.96
2 1/2	65	3.62	92.00	4.80	122.00	2.25	57.15	4.58	10.07
3	80	3.74	95.00	5.43	138.00	2.63	66.70	6.03	13.26

Corroline⁺ Integral PTFE Lined Flange Fittings & 'Step - Up' Design

Flange Specifications

- ANSI B16.5 (also ASME B16.5) Class 150# and 300#
- *DIN PN10, PN16 and PN40
- JIS 10K
- Other Pressure Ratings and Flange Specifications are also available.

*DIN PN10, PN16 and PN40 Flanges all have the same dimensions, and so are fully interchangeable

Maximum Pressure Ratings for Flange Fittings

- ANSI 150# = 16 Bar (230 psi), ANSI 300# = 41.4 Bar (600 psi)
- DIN PN10 = 10 Bar (145 psi), DIN PN16 = 16 Bar (230 psi)

End Fitting Materials

- Flanges in Grade 304 SS
- Flange Retainers in Grade 316L SS
- Ferrules, most in Grade 304 SS, some sizes in Grade 316 SS

Alternative Options for Flange Component only:

- Zinc Plated Carbon Steel
- Grade 316SS

90° Elbow Flange Fittings

- 90° Elbow Integral PTFE lined Flange Fittings are available for sizes 1", 1 1/2" and 2" - Consult Aflex Hose for details.

Integral PTFE Lined Flange Fittings

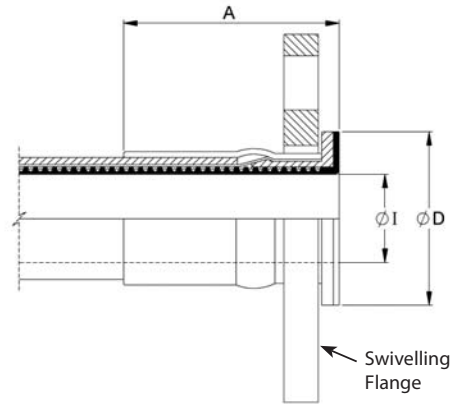

Nominal Hose Size		*Fitting Length A ASA		*Fitting Length A PN		Flared Diameter D				Fitting Inside Dia. & Hose Bore I		Recommended Bolt Tightening Torques		Weight of Fitting	
						ASA 150#		*DIN PN10/16/40							
in	mm	in	mm	in	mm	in	mm	in	mm	in	mm	ft.lbs	mtr.kgs	Kg	Lbs
1/2	13	2.24	57.0	2.28	58	1.25	32	1.25	32	1/2	13.2	8	1.10	0.54	1.20
3/4	20	1.89	48.0	1.93	49	1.69	43	1.97	50	3/4	19.4	8	1.10	0.88	1.90
1	25	2.40	61.0	2.48	63	2.00	50	2.50	63	1	25.2	10	1.40	0.96	2.10
1 1/4	32	2.24	57.0	2.32	59	2.48	63	3.10	78	1 1/4	32.0	12	1.66	1.15	2.53
1 1/2	40	2.36	60.0	2.44	62	2.875	73	3.50	88	1 1/2	38.6	15	2.10	1.75	3.80
2	50	2.72	69.0	2.91	74	3.625	92	4.00	102	2	51.2	25	3.50	2.70	5.95
2 1/2	65	4.86	123.5	4.86	123.5	4.13	105	4.80	122	2 1/2	63.7	30	40.18	4.21	9.26
3	80	5.17	131.4	5.17	131.4	5.00	127	5.00	127	3	76.8	40	53.94	4.75	10.44

*The listed Flare Diameters for 1/2", 3/4" and 1" DIN PN10/16/40 are not all full size due to limitations on PTFE flare diameters.

'Step-Up' PTFE Lined Flange Fitting Design for Corroline⁺ Hose

Because Corroline⁺ Hose has better flow rates than some larger bore sizes of Convuluted PTFE hose, it represents a superior alternative when fitted with the larger size flanges in some applications.

It is, however, necessary to also "Step-Up" the PTFE-lined bore, to ensure a diameter match with the mating connector.

This is best achieved using a solid PTFE Adaptor Plate, as shown in the drawing.

Example: a 2" hose to 3" ANSI 150# PTFE Lined Flange Joint >

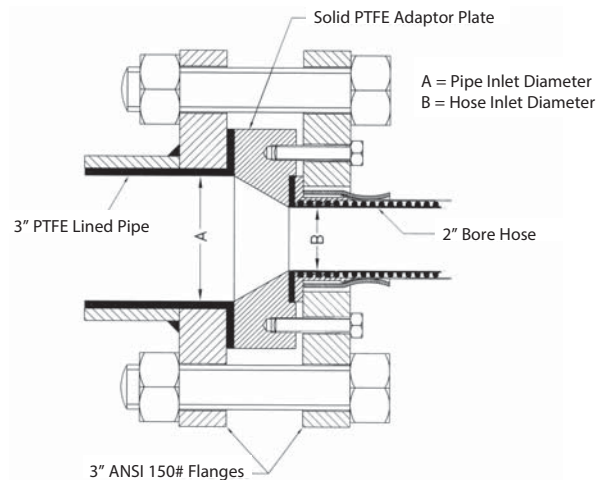

Corroline⁺ Female Cam & Groove Fittings

PTFE Lined & Non-Lined

End Fitting Specifications

- Generally in accordance with A-A-59326 (replaces MIL-C-27487) and EN14420-1 (replaces DIN 2828), and all are fully interchangeable.

End Fitting Materials

- Spigot in Grade 316L SS
- Body in Grade 316C SS
- Ferrules, most in Grade 304 SS, some sizes in Grade 316L SS
- Standard Gasket is Buna N (Nitrile) Rubber.
- FEP encapsulated Silicone Rubber Gaskets also available.

Surface Finish: (Non-Lined Fittings only)

- All surface finishes are to ASME BPE-SF-O (No finish required).
- If a specified finish on a particular surface is required, please state on the enquiry and order.

Temperature and Pressure Ratings

- When used with a Buna N Gasket all sizes up to 16 Bar (230 psi) and up to a maximum temperature of 65°C (149°F).
- When used with FEP, Fluoro Rubber or other encapsulated gaskets all sizes up to 10 Bar (145 psi) and up to a maximum temperature of 204°C (400°F).

90° Elbow Cam & Groove Fittings (PTFE Lined Only)

- 90° Elbow Integral PTFE lined Cam & Groove Fittings are available for sizes 1", 1½" and 2" - Consult Aflex Hose for details.

Notes for Integral PTFE Lined Fittings Only:

- FEP Gaskets require higher clamping forces to flatten the Seal and make the joint. This is made easier by 'pre-setting' these gaskets by clamping Polypropylene Cam Male Inserts to the assembled fittings, which must then be kept in place during storage, until use.
- Any Customer's Own 'Special' Gaskets must be pre-supplied to Aflex for special assembly and testing of hose assemblies, to ensure suitability.

Swivelling, Locking Arm Female Cam and Groove Fittings - Non-Lined

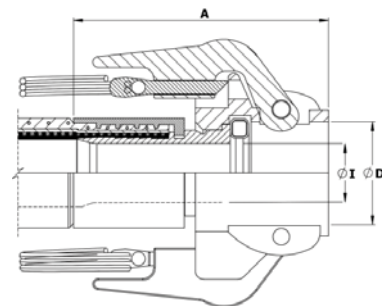

Nominal Hose Size		*Fitting Length A		Cam Sleeve Inside Diameter D		Fitting Inside Diameter I		Weight of Fitting	
in	mm	in	mm	in	mm	in	mm	Kg	Lbs
¾	20	2.10	53.00	1.26	32.0	0.62	15.75	0.58	1.28
1	25	2.32	59.00	1.45	37.0	0.85	21.50	0.72	1.58
1¼	32	2.54	64.60	1.81	46.0	1.03	26.21	1.10	2.42
1½	40	2.65	67.20	2.12	54.0	1.25	31.75	1.21	2.66
2	50	3.11	79.00	2.52	64.0	1.76	44.60	1.48	3.26
2½	65	2.99	76.00	3.01	76.5	2.25	57.15	1.42	3.12
3	80	2.80	71.00	3.63	92.2	2.63	66.70	1.88	4.14

Fixed or Swivelling, Locking Arm Female Cam and Groove Fitting - Integral PTFE Lined

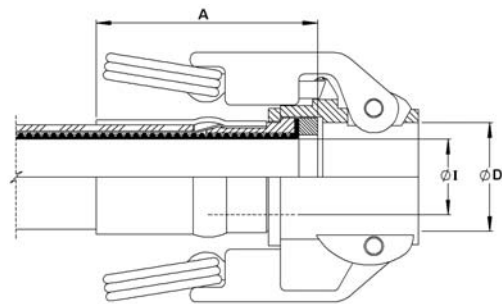

Nominal Hose Size		*Fitting Length A		Cam Sleeve Inside Diameter D		Fitting Inside Diameter I		Weight of Fitting	
in	mm	in	mm	in	mm	in	mm	Kg	Lbs
¾	20	2.16	54.75	1.26	32.0	0.76	18.6	0.42	0.93
1	25	2.72	69.00	1.46	37.0	1.01	25.2	0.59	1.30
1¼	32	2.56	65.50	1.81	46.0	1.26	32.0	0.98	2.16
1½	40	2.61	66.35	2.13	54.0	1.53	38.6	1.15	2.50
2	50	2.97	75.35	2.52	64.0	2.03	51.2	1.40	3.08
*2½	65	5.31	135.0	3.01	76.5	2.36	60.0	1.17	2.57
*3	80	5.45	138.4	3.63	92.2	2.87	73.0	1.40	3.07

*PTFE lined 2½" and 3" sizes are fixed only

Corroline⁺ Male Cam & Groove Fittings & Lined Flange Adaptors

End Fitting Specifications

- Generally in accordance with A-A-59326 (replaces MIL-C-27487) and EN14420-1 (replaces DIN 2828), and all are fully interchangeable.

Temperature and Pressure Ratings

- Temperature and pressure determined by the type of gasket in the Female connecting component and the hose grade.

End Fitting Materials

- Fittings in Grade 316L SS
- Ferrules, most in Grade 304 SS, some sizes in Grade 316L SS
- Adaptor Flange Only in Grade 304 SS

Surface Finish: (Non-Lined Fittings only)

- All surface finishes are to ASME BPE-SF-O (No finish required).
- If a specified finish on a particular surface is required, please state on the enquiry and order.



Non-Lined Cam & Groove Male Fitting

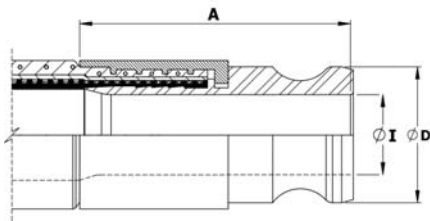

Integral PTFE Lined Cam & Groove Male Fitting

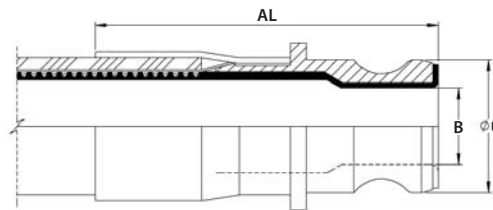

Nominal Hose Size		Outside Diameter D		Non-Lined Fitting Length A		Non-Lined Inside Diameter I		PTFE Lined Fitting Length AL		PTFE Lined Inside Diameter B		Weight of Fitting Non-Lined		Weight of Fitting PTFE Lined	
in	mm	in	mm	in	mm	in	mm	in	mm	in	mm	Kg	Lbs	Kg	Lbs
3/4	20	1.26	32.0	2.40	61.0	0.62	15.75	2.82	71.58	0.71	18.6	0.22	0.49	0.35	0.77
1	25	1.46	37.0	3.00	77.0	0.85	21.50	3.74	95	0.81	20.7	0.33	0.72	0.45	0.99
1 1/4	32	1.79	45.5	3.54	90.0	1.03	26.21	3.62	92	0.97	24.8	0.57	1.25	0.45	1.09
1 1/2	40	2.11	53.5	3.70	94.0	1.25	31.75	3.98	101	1.35	33.5	0.78	1.71	0.84	1.85
2	50	2.48	63.0	4.45	113.0	1.76	44.60	4.61	117	1.72	41.5	1.08	2.37	1.10	2.42
2 1/2	65	2.98	75.8	4.13	105.0	2.23	56.6	6.50	165	2.17	55.0	1.22	2.68	1.17	2.57
3	80	3.60	91.5	4.76	120.8	2.87	73.0	6.98	177.4	2.84	72.2	1.79	3.94	1.45	3.20

PTFE Lined Male Cam & Groove X Flange Adaptors

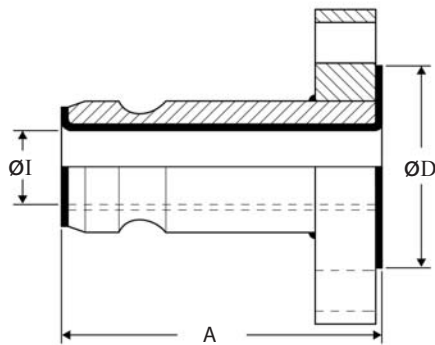

AS Grade PTFE Liner

GP Grade PTFE Liner



Note: Other Flange Specifications and Pressure Ratings are also available. Non-Lined adaptors and Female Cam & Groove X Flange Adaptors are also available, to special order.

Cam Action Adaptor Size		Flange Size & Specification	ØD		A		ØI		Weight of Fitting	
in	mm		in	mm	in	mm	in	mm	Kg	Lbs
1	25	1" ANSI 150	2.00	50	4 7/8	105	0.84	21	1.246	2.75
1	25	DN25/PN16	2.58	64	4 7/8	105	0.84	21	1.538	3.39
1 1/2	40	1 1/2" ANSI 150	2.87	73	4 3/8	118	1.35	34	2.228	4.92
1 1/2	40	DN40/PN16	3.47	88	4 3/8	118	1.35	34	2.753	6.07
2	50	2" ANSI 150	3.63	92	4 3/8	118	1.69	43	3.359	7.40
2	50	DN50/PN16	4.00	102	4 3/8	118	1.69	43	3.714	8.19

Corroline⁺ Sanitary & Mini-Sanitary Triclover Fittings



Introduction

There are many different specifications, dimensions and surface finishes for triclover fittings. Those listed below are the popular fittings, which are stocked as standard fittings by Aflex.

All the alternative fittings can be supplied to special order if the following information can be given;

- Flange diameter D and Outlet diameter I
- Hose size if known, or Aflex can recommend a hose size to suit
- The internal Surface Finish, if it is required to be better than the ASME BPE SF3 surface finish of $<0.76\mu\text{m.Ra} = <30\mu\text{ in Ra}$ non-electropolished.
- Standard (see below) if known.

Standards

- ASME BPE
- DIN 32676 (types A, B and C are available)
- BS 4825 Pt.3 (equivalent to ASME BPE)
- ISO 1127

End Fitting Materials

- Fittings in AISI 316L = EN 1.4404 = BS 316 S11
- Ferrules, most in Grade 304 SS, some sizes in Grade 316L SS
- Fittings for DIN32676 are available in 1.4435 (316L)
- Fittings in 1.4571, Hastelloy, Monel, PVDF and other materials to special order

Temperature and Pressure Ratings

- Pressures up to 16 Bar (230 psi)
- Temperatures up to 120°C (250°F) with EPDM Gaskets
- Temperatures up to 180°C (356°F) with PTFE, Silicone or Viton Gaskets
- Higher Pressures and Temperatures with Special Clamps and Gaskets.

Internal Surface Finish Specifications

- ASME BPE SF3 (mechanical polish, not electropolished) Surface Finish, Maximum reading: $<0.76\mu\text{m Ra} = <30\mu\text{ in. Ra}$
- ASME BPE SF4 (mechanical polish and electropolished) Surface Finish, Maximum reading: $<0.375\mu\text{m Ra} = <15\mu\text{ in. Ra}$ (SF4 is the highest level of surface finish specified in ASME BPE, and the standard, stocked fittings listed are all to this finish).
- DIN 32676 H4 (mechanical polish, not electropolished) Surface Finish, Average reading: $<0.4\mu\text{m Ra} = <16\mu\text{ in. RA}$ If the standard SF4 finish is not acceptable, H4 must be requested on the enquiry/order.

Note: ASME BPE Triclover suppliers often quote an 'Average' of surface finish reading only, for example 'average 15 Ra or better', but this is not in accordance with the stricter ASME BPE requirement that a 'Maximum' for individual readings should be complied with.

Standard Fittings Available:

	Nominal Hose Size		Flange Diameter D		Outlet Diameter I		Fitting Length A		Specifications	
	in	mm	in	mm	in	mm	in	mm	ASME BPE	DIN 32676
Mini-Sanitary Triclover Fittings	1/4	0.984	25.0	0.172	4.37	1.3	33	-SF4	-	
	1/4	0.984	25.0	3/8	9.53	1.3	33	-SF4	Type C	
	3/8	0.984	25.0	0.305	7.75	1.7	42	-SF4	-	
	3/8	0.984	25.0	3/8	9.53	1.7	42	-SF4	Type C	
	1/2	0.984	25.0	5/8	15.88	1.7	44	-SF4	Type C	
	1/2	0.984	25.0	3/8	9.5	1.7	44	-SF4	Type C	
	3/4	0.984	25.0	5/8	15.85	2.0	50	-SF4	Type C	
Sanitary Triclover Fittings	3/4	1.340	34.0	5/8	15.88	2.0	50	-SF4	Type C	
	3/4	1.340	34.0	0.630	16.0	2.0	50	-	Type A	
	1/2	1.984	50.5	7/8	22.2	1.7	44	-SF4	Type C	
	1/2	1.984	50.5	1 3/8	34.8	1.7	44	-SF4	Type C	
	3/4	1.984	50.5	0.713	18.1	1.8	45	ISO1127	Type B	
	3/4	1.984	50.5	7/8	22.1	1.8	45	-SF4	Type C	
	3/4	1.984	50.5	5/8	15.88	1.8	45	-SF4	Type C	
	1	1.984	50.5	7/8	22.2	2.3	58	-SF4	Type C	
	1	1.984	50.5	1 3/8	34.8	2.3	58	-SF4	Type C	
	1 1/2	1.984	50.5	1 3/8	34.8	2.6	67	-SF4	Type C	
	1 1/2	2.516	64.0	1 7/8	47.6	2.6	67	-SF4	Type C	
	2	2.516	64.0	1 7/8	47.6	3.1	78	-SF4	Type C	
	2 1/2	3.05	77.5	2.37	60.2	2.80	71	-SF4	Type C	
	3	3.58	91	2.87	72.9	3.17	80.4	-SF4	Type C	

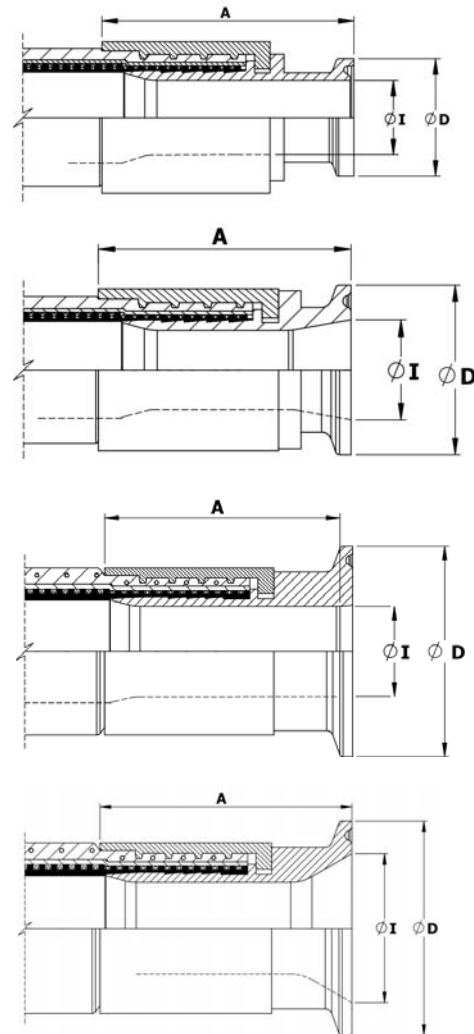

Mini-Sanitary Triclover Fittings

Sanitary Triclover Fittings

Corroline⁺ Sanitary Triclover Fittings - 90° Elbow

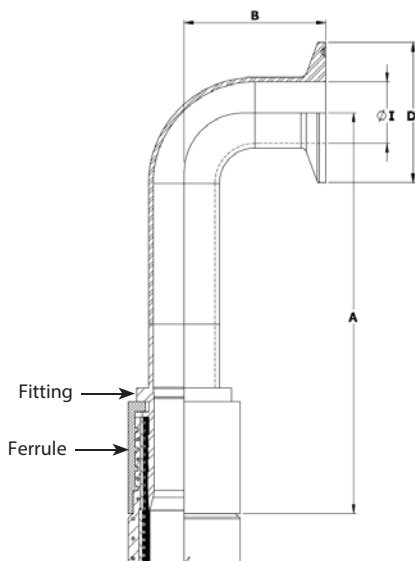

End Fitting Specifications

- BS4825 Pt 3
- ASME-BPE-a
- Others to Special Order

End Fitting Materials

- Fittings in Grade AISI 316L = EN 1.4404 = BS 316 S11
- Ferrules, most in Grade 304 SS, some sizes in Grade 316L SS

Surface Finish :

- The internal surface is to ASME BPE-SF-3 (<0.76 µm Ra, not electropolished).
- If a specified finish on a particular surface is required, please state on the enquiry and order.

Outlet Diameters

The outlet diameters as listed are in accordance with BS4825. The ASME specification, however, requires these diameters to be 0.005" (0.125mm) less in each case. An Outlet Diameter tolerance of +0.000 -0.005" has therefore been applied, so that the same fitting satisfies requirements of both specifications.

Temperature and Pressure Ratings

- Pressures up to 16 Bar (230 psi)
- Temperatures up to 120°C (250°F) with EPDM Gaskets
- Temperatures up to 180°C (356°F) with PTFE, Silicone or Viton Gaskets
- Higher Pressures and Temperatures with Special Clamps and Gaskets.

Standard Fittings Available:

Nominal Hose Size		*Centre Line to Fitting End A		Centre Line to Face B		Flange Diameter D		Outlet Diameter I		Weight of Fitting	
in	mm	in	mm	in	mm	in	mm	in	mm	Kg	Lbs
1/2	13	5.12	130.0	1.60	41.0	0.98	25.0	3/8	9.5	0.09	0.21
3/4	20	5.26	133.5	1.60	41.0	0.98	25.0	5/8	16.0	0.14	0.30
1	25	5.64	143.2	2.00	51.0	1.98	50.5	7/8	22.2	0.26	0.58
1 1/2	40	6.69	170.0	2.75	70.0	1.98	50.5	1 3/8	34.9	0.45	1.00
2	50	8.10	205.7	3.50	88.9	2.16	64.0	1 7/8	47.6	0.75	1.65
2 1/2	65	7.32	186.0	4.25	108.0	3.05	77.5	2.37	60.2	1.48	3.25
3	80	10.43	265.0	5.00	127.0	3.58	91.0	2.87	72.9	1.99	4.38

Corroline⁺ DIN11851 Male and Female Fittings

End Fitting Materials

- Spigots in Grade 316L SS (Non-Lined Spigot in 1.4571*)
- Nuts in Grade 304 SS
- Ferrules, most in Grade 304 SS, some sizes in Grade 316L SS

* 1.4571 is a special grade of 316 stainless steel, equivalent to AISI 316Ti

Surface Finish:

- All surface finishes are to ASME BPE-SF-3 > 0.76 µm Ra mechanical polish.
- If a specified finish on a particular surface is required, please state on the enquiry and order.

End Fitting Specifications

- Generally to DIN 11851 specifications.

Temperature & Pressure Ratings

- Sizes up to 1½" MWP = 40 Bar (580 psi) up to 140°C (284°F)
- Sizes 2" to 3" MWP = 25 Bar (360 psi) up to 140°C (284°F)

Except where hose pressure ratings are lower (page 6)

DIN11851 Female Fitting - Non Lined

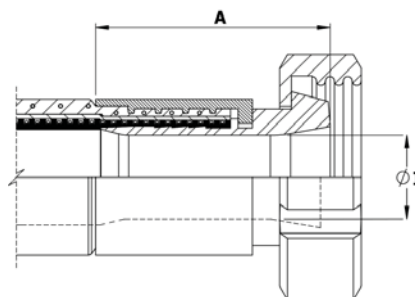

Nominal Hose Size		I Diameter		Fitting Length A		Weight of Fitting	
in	mm	in	mm	in	mm	Kg	Lbs
½	15	0.37	9.4	1.63	41.5	0.20	0.44
¾	20	0.62	15.8	1.87	47.5	0.34	0.76
1	25	0.85	21.5	2.33	59.2	0.49	1.08
1¼	32	1.03	26.2	2.58	65.5	0.64	1.40
1½	40	1.25	31.8	2.76	70.0	0.85	1.86
2	50	1.76	44.6	3.23	82.0	1.20	2.04
2½	65	2.25	57.2	3.03	77.0	1.59	3.50
3	80	2.63	66.7	2.97	75.5	2.04	4.49

DIN11851 Male Fitting - Non Lined

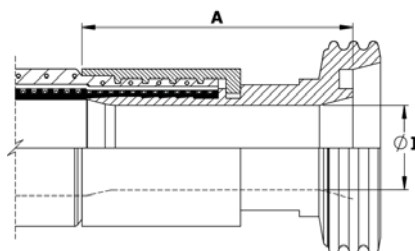

Nominal Hose Size		I Diameter		Fitting Length A		Weight of Fitting	
in	mm	in	mm	in	mm	Kg	Lbs
½	15	0.37	9.4	1.82	46	0.14	0.30
¾	20	0.62	15.8	2.05	52	0.28	0.62
1	25	0.85	21.5	2.68	68	0.40	0.87
1¼	32	1.03	26.2	2.48	63	0.55	1.21
1½	40	1.25	31.8	2.84	72	0.76	1.68
2	50	1.76	44.6	3.23	82	0.92	2.04
2½	65	2.25	57.15	3.23	82	1.27	2.79
3	80	2.63	66.7	3.23	82	1.62	3.56

Corroline⁺ 37° JIC Female Fittings and NPT Male & Female Unions

37° JIC Female Fitting

End Fitting Specifications

- SAE J514 37° Flare JIC Female Fitting
- 37° JIC Male-to-NPT Male/Female Adaptors
- NPT Threads to ANSI/AMSE B1.20.1

Temperature and Pressure Ratings

- Same Maximum Working Pressure and Temperature as for the relevant size of Corroline⁺ Hose, on page 6.

Note: Not usable with SAE 45° Flare fittings which have the same thread.

End Fitting Materials

- Spigots in Grade 316L SS
- Nuts in 316L SS
- Ferrules, most in Grade 304 SS, some sizes in Grade 316L SS

Alternatives:

- Available in other materials to special order

Surface Finish :

- All surface finishes are to ASME BPE-SF-O (No finish required).
- If a specified finish on a particular surface is required, please state on the enquiry and order.

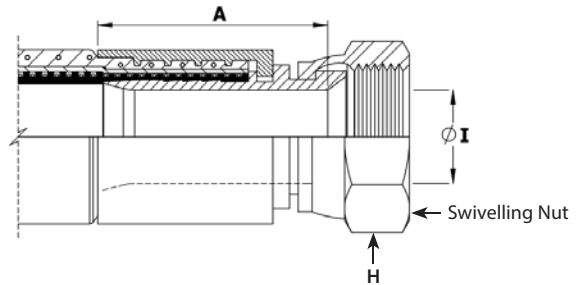

Nominal Hose Size		37° JIC Thread Size	*Fitting Length A		Hex Size H		Fitting Inner Diameter I		Weight of Fitting	
in	mm	in	in	mm	in	mm	in	mm	Kg	Lbs
1/2	13	3/4 - 16	1.57	40	0.88	22.2	0.37	9.40	0.09	0.20
3/4	20	1 1/16 - 12	1.89	48	1.25	31.7	0.62	15.75	0.20	0.44
1	25	1 5/16 - 12	2.28	58	1.50	38.1	0.85	21.50	0.30	0.66
1 1/2	40	1 7/8 - 12	2.72	69	2.25	57.1	1.25	31.75	0.62	1.37
2	50	2 1/2 - 12	3.27	83	2.88	73.0	1.76	44.60	1.10	2.42

JIC to NPT Male Union (including a JIC Male to NPT Male Adaptor)

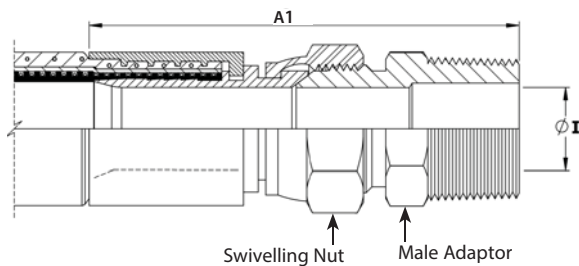

Nominal Hose Size		*Male Union Length A1		Weight of Fitting	
in	mm	in	mm	Kg	Lbs
1/2	13	2.95	75	0.17	0.37
3/4	20	3.74	95	0.34	0.75
1	25	4.49	114	0.64	1.40

JIC to NPT Female Union (including a JIC Male to NPT Female Adaptor)

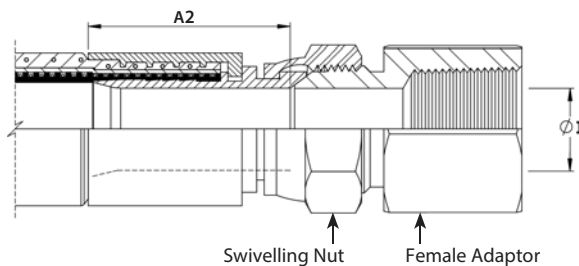

*Female Union Length A2		Fitting Inner Diameter I		Weight of Fitting	
in	mm	in	mm	Kg	Lbs
3.07	78	2.95	75	0.17	0.37
3.78	96	3.74	95	0.34	0.75
4.17	106	4.49	114	0.64	1.42

Corroline⁺ NPT and BSPT Fixed Male & NPT Fixed Female Fittings

End Fitting Specifications

- NPT Taper Threads to American National Standard Pipe Taper Thread design to ANSI/AMSE B1.20.1.
- BSPT Threads to British Standard Pipe Taper Thread design to BS21

Alternatives - Parallel Threads, Metric Threads and Others.

End Fitting Materials

- Fittings in Grade 316L SS
- Ferrules, most in Grade 304 SS, some sizes in Grade 316L SS
- Available in other materials to special order

Alternatives - Hydraulic design BSPT Male Fittings in Zinc Plated Carbon Steel, to special order.

Surface Finish :

- All surface finishes are to ASME BPE-SF-O (No finish required).
- If a specified finish on a particular surface is required, please state on the enquiry and order.

Fixed Male NPT or BSPT

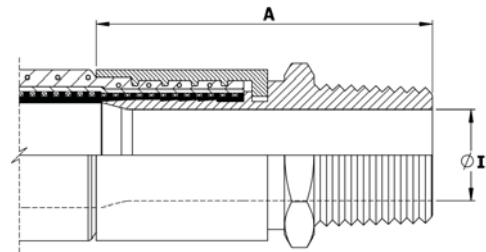

Nominal Hose Size		NPT or BSPT Thread Size	*Fitting Length A		Fitting Inside Diameter I		Weight of Fitting	
in	mm		in	mm	in	mm	Kg	Lbs
1/2	13	1/2	2.40	61	0.37	9.40	0.14	0.30
3/4	20	3/4	2.68	68	0.62	15.75	0.25	0.54
1	25	1	3.07	78	0.85	21.50	0.33	0.73
1 1/4	32	1 1/4	3.58	91	1.03	26.21	0.61	1.34
1 1/2	40	1 1/2	3.82	97	1.25	31.75	0.81	1.78
2	50	2	4.57	116	1.76	44.60	1.17	2.58
2 1/2	65	2 1/2	5.31	135	2.25	57.15	1.84	4.04
3	80	3	5.39	137	2.63	66.7	2.49	5.47

Fixed Female NPT

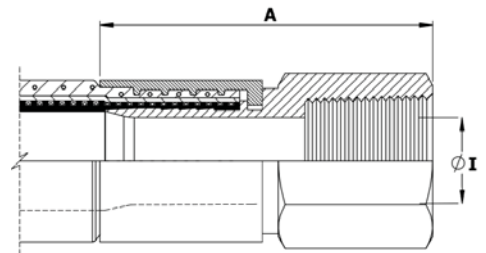

Nominal Hose Size		NPT Thread Size	*Fitting Length A		Fitting Inside Diameter I		Weight of Fitting	
in	mm		in	mm	in	mm	Kg	Lbs
1/2	13	1/2	2.40	61	0.37	9.40	0.18	0.39
3/4	20	3/4	2.52	64	0.62	15.75	0.24	0.54
1	25	1	3.23	82	0.85	21.50	0.37	0.81
1 1/2	40	1 1/2	3.62	92	1.25	31.75	0.83	1.82
2	50	2	4.13	105	1.76	44.60	1.24	2.72

Corroline⁺ BSP 60° Cone Seat Female Unions and Non-Lined Tube Adapter (Grooved Standpipe) Fittings

End Fitting Specifications

- BSPP Threads to British Standard Pipe Parallel Thread design to BS21, 60° Cone Seat design, or Flat Seat.

End Fitting Materials

- Spigots in Grade 316L SS
- Nuts in Grade 316L SS
- Ferrules, most in Grade 304 SS, some sizes in Grade 316L SS

Alternatives:

- Hydraulic design Cone Seat Female Unions can be supplied in Zinc Plated Carbon Steel to special order.
- Lug Nuts can be supplied in Gun Metal (Bronze) if required.

Surface Finish :

- All surface finishes are to ASME BPE-SF-O (No finish required).
- If a specified finish on a particular surface is required, please state on the enquiry and order.

BSP 60° Cone Seat Female Union Fitting

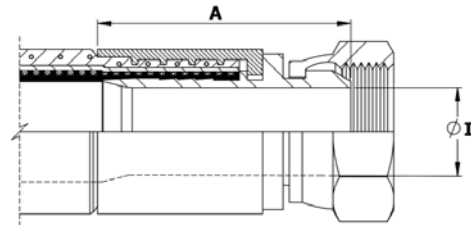

Nominal Hose Size		NPT or BSPT Thread Size	*Fitting Length A		Fitting Inside Diameter I		Weight of Fitting	
in	mm		in	mm	in	mm	Kg	Lbs
1/2	13	1/2	1.46	37	0.37	9.40	0.09	0.21
3/4	20	3/4	1.89	48	0.62	15.75	0.20	0.44
1	25	1	2.17	55	0.85	21.50	0.33	0.72
1 1/4	32	1 1/4	2.48	63	1.03	26.21	0.49	1.07
1 1/2	40	1 1/2	2.87	73	1.25	31.75	0.79	1.73
2	50	2	2.91	74	1.76	44.60	1.07	2.36
2 1/2	65	2 1/2	3.15	80	2.25	57.15	1.37	3.02
3	80	3	3.21	81.5	2.63	66.7	2.10	4.62

Non-Lined Tube Adapter (Grooved Standpipe) Fitting

End Fitting Specifications

- Compatible with existing Industrial Standard Tube Fitting Components.

End Fitting Materials

- Fitting in grade 316L SS
- Ferrule (for hose attachment) in Grade 304 or 316L SS

Alternatives can be supplied with matching Female nuts & Ferrules (clamping Ferrules) to suit.

Surface Finish:

- All surface finishes are to ASME BPE-SF-O (No finish required).
- If a specified finish on a particular surface is required, please state on the enquiry and order.

Temperature & Pressure Ratings

- As for the relevant size of hose on Page 6.

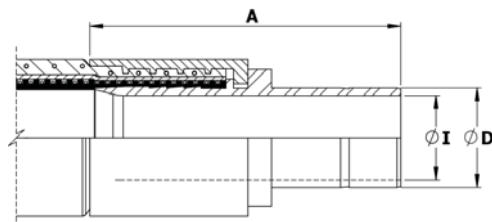

Nominal Hose Size		Fitting Length A		Diameter D		Fitting Inside Diameter I		Weight of Fitting	
in	mm	in	mm	in	mm	in	mm	Kgs	Lbs
3/4	20	2.48	63	3/4	19.05	0.62	15.75	0.16	0.35
1	25	2.87	73	1	25.40	0.85	21.50	0.25	0.55

Corroline⁺ Dip Pipes, Straight or 90° Elbow

Fixed Dip Pipes

Description

Fixed Dip Pipes are fairly rigid, thick wall PTFE tubes, either straight or 90° elbowed, which are directly crimped to the end of Corroline⁺ hoses. They are designed for insertion into drums, tanks and reaction vessels in order to suction drain (or inject) process fluids transferred through the hose.

Materials

- Standard dip pipes are in anti-static (AS) PTFE
- Ferrules, most in Grade 304 SS, some sizes in Grade 316L SS

How to order

Specify the size and material of the dip pipe, whether it is straight or 90° elbowed. Give the length of the straight leg of the dip pipe and the length of the rest of the hose assembly separately.

Maximum Working Pressures

Dip Pipes are normally only tested to 6 Bar Pressure, and are not suitable for use at pressures higher than 3 Bar. They are usable at negative pressure up to -0.9bar vacuum.

If higher pressure ratings are required, consult Aflex Hose.

Lengths

Dip Pipes are supplied as standard in 1 metre straight lengths, but can be supplied in any length to individual requirements.

Note: Not available as a Hydraulic Fitting.

Nominal Hose Bore Size		Approximate Dip Pipe Dimensions			
		Outside Diameter D		Inside Diameter I	
in	mm	in	mm	in	mm
3/4	20	0.87	22	0.51	13
1	25	1.14	29	0.83	21
1 1/2	40	1.54	39	1.00	27
2	50	2.17	55	1.58	40

Detachable Dip Pipes

Description

As Fixed Dip Pipes above, but connected to the hose through an end fitting, not by crimping direct to the hose.

Design

A straight, or 90° elbowed anti-static PTFE Dip Pipe, fitted with a Flange or Cam & Groove Male PTFE Lined & Flared end fitting.

The most usual end fitting is a Cam Male (as shown), so the dip pipe can then be connected to a hose with a Cam Female end fitting.

Specifications

As above for Fixed Dip Pipes

Fixed Dip Pipe (90° Elbow)



Fixed Dip Pipe (Straight)

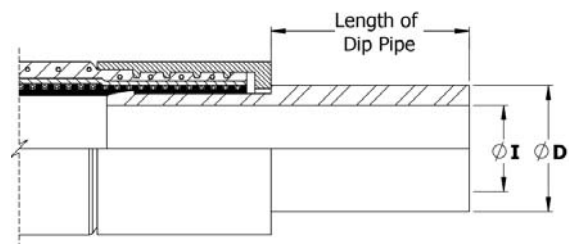

Detachable Dip Pipe

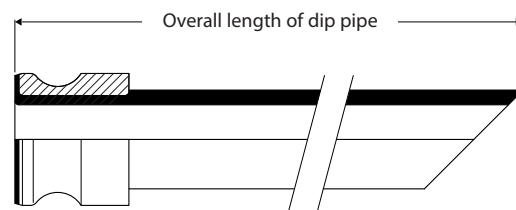

Corroline⁺ Standard Labelling and Colour Coding Systems

Standard Labelling

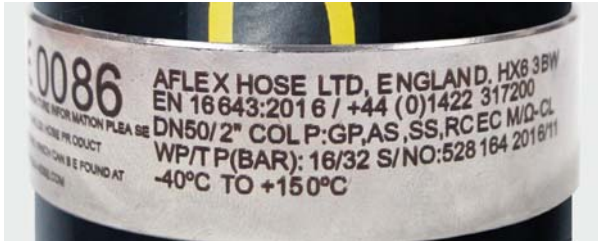

All Corroline⁺ hose assemblies are labelled with the following information:

Manufacturer's Name (Aflex Hose Ltd)

Hose Size and Grade

EN16643 and year of standard publication

EN16643 Electrical Property Grade

Max. Working Pressure and Test Pressure

Working Temperature Range

Unique Serial Number

Month & Year of Manufacture

Aflex Hose Telephone Number

CE Mark (if applicable)

This information is normally laser-etched on to a loose stainless steel ring mounted on the hose.

In some cases, at the discretion of Aflex Hose, the information may be etched on to a thin stainless steel plate which is clamped to the hose, or on to the end fitting ferrule at one end. This may be necessary for example, if the customer requires additional information which may not fit on to a Ring.

Customers may specify which labelling system they require, and may request additional information on the label.

Colour Coding

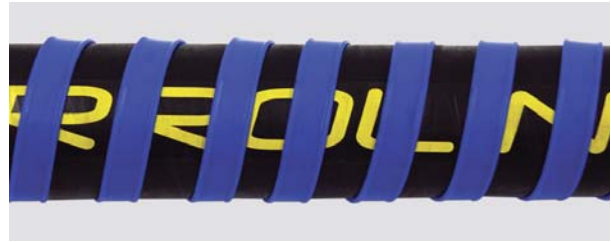

A coloured PTFE spiral strip is wound on to the hose.

It can be left loose, or it can be encapsulated under a transparent, heat-shrunk polyolefin sleeve.

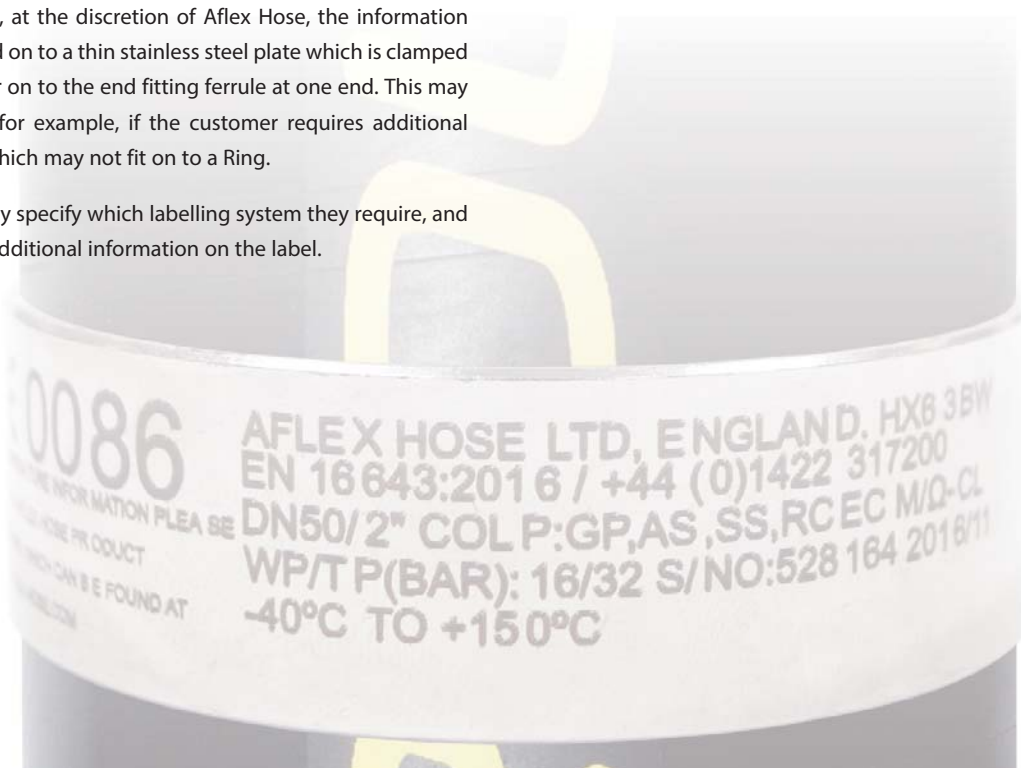

Corroline⁺ Hose: Special Usage Conditions

- **Cleaning & Sterilising Systems - CIP, SIP and Autoclave**

CIP & SIP – PTFE liner tubes are chemically resistant to all CIP, SIP and Autoclave conditions. A primary consideration is whether the cleaning and purging cycle is likely to develop an electrostatic charge on the internal surface of the liner, in which case AS (Anti-Static) grade hose is required.

AS grade hose and Electrostatic charge generating systems are fully described in the hose liner section.

CIP systems using high electrical resistivity solvents like Toluene will require AS grade hose.

Another electrostatic generation problem arises when wet steam is passed through, or when the cleaning fluids or WFI are purged out of the line using nitrogen, compressed air or another gas, because droplets of liquid or water in the gas then generate a multi-phase condition until they are cleared out, which will generate a static charge, and so will require AS grade hose.

- **Autoclave**

Corroline⁺ hose is able to withstand at least 100 x 30 minute autoclave cycles at relatively high autoclave temperatures (upto 135°C, 275°F). Consult Aflex Hose for more specific information.

- **PTFE Hose-Use with Alkali Metals, Halogens and certain Halogens containing Chemicals**

PTFE hose liners react chemically with Fluorine, Chlorine Trifluoride and molten Alkali Metals and so no hose grades are suitable for use with these chemicals.

When PTFE lined hose is used to carry Chlorine or Bromine, either as gasses or fluids, trace quantities can diffuse into and through the PTFE liner wall thickness. These will then combine with atmospheric moisture to corrode the SS braid or rubber cover outside the liner tube. It has been found that Corroflon SP, HB or KYB hose is best suited for these applications - Please consult the Corroflon brochure.

Depending upon the internal pressures and temperatures, some other gasses and fluids with a high halogen content may also be transmitted in trace quantities through the wall of the PTFE tube, including Hydrogen Fluoride, Hydrogen Chloride, Carbonyl Chloride (Phosgene), Carbon Tetrachloride and others. Please consult with Aflex Hose for a suitable hose grade recommendation.

- **Other “Penetrating” Fluids and Gases**

Sulphur Trioxide, Methyl Methacrylate, Caprolactam and Glacial Acetic Acid are some other chemicals which do not react chemically with the PTFE, but which can be absorbed and transmitted in trace quantities through the PTFE liner tube wall - please consult Aflex Hose for the optimum solution with these chemicals.

Generally, however, as a hydrophobic (non-wetting) material, PTFE is very resistant to the absorption of chemicals. In some cases, PTFE has superior resistance to diffusion, for example to the diffusion of automotive fuels, in comparison with all other plastics and rubbers.

- **Gas/Fluid Cycling**

There are some applications where fluids then gasses are passed through the hose, in a cyclic sequence.

This is normally associated with changes in temperature and/or pressure. For complex reasons these conditions are extremely damaging to the hose liner, whatever material it is made from.

For example, hoses are sometimes used to pass steam, water, steam etc into rubber moulding presses, in order to heat the mould, then rapidly cool it before reheating in the next cycle. Hoses of all types fail rapidly in such an application and PTFE lined hoses are no exception.

Please contact Aflex Hose for further information if these conditions apply.

- **Connecting Assemblies for Use in Applications**

The lengths of hose assemblies and their configuration in use when connected into the application must always be in accordance with the Hose Configuration information at the end of this product literature.

When being connected for use in applications, the end fittings on hose assemblies must be connected to correct mating parts in the correct way, using the correct tools, spanners, clamps, nuts and bolts etc. The connections must be sufficiently tightened to ensure that the joint is leak free but not be over tightened as this can damage the sealing surfaces, especially with PTFE lined and flared end fittings.

In applications involving the transfer through the hose of expensive or dangerous fluids or gases, the hoses and connections must be pressure tested in situ before being put in to service. This should be done with some harmless media to 2.0 times the maximum working pressure of the hose assembly, as stated in the product literature.

If in doubt please contact Aflex Hose for advice.

- **Special Applications**

Aflex Hose PTFE lined hose products are not rated as suitable for use in the following, special applications:

- All Radioactive Applications involving high energy radiation, including Gamma radiation (degrades PTFE)
- All Medical Implantation Applications.
- All Aerospace Applications, except by special prior agreement, confirmed in writing.

- **Silicone-Free Application requirements**

Some applications, particularly paint manufacturing plants, and other specialised applications require that hoses do not include any silicone containing materials in their manufacture, or sometimes that hoses are guaranteed to be 100% Silicone Free. Customers or Distributors must specifically identify and define any such requirements in writing on all enquiries/orders.



Quality Assurance, Certification and Approvals, and Hose Testing

BS EN ISO 9001:2008

Aflex products are all manufactured in accordance with BS EN ISO 9001 Quality Management Systems independently assessed and registered by The British Standards Institution (BSI).

EN 16643

Corroline⁺ meets the requirements of EN 16643 (type SC), which include the electrical and electrostatic requirements of hose assemblies.

TS16949

Aflex Hose Ltd manufactures PTFE flexible hose for the automotive industry in accordance with TS16949 and is assessed and certified by The British Standards Institution (BSI).

ISO 14001

Aflex Hose Ltd have been successfully assessed to the requirements of ISO 14001, by the British Standards Institution (BSI). By gaining this accreditation Aflex Hose Ltd are demonstrating our commitment to reducing our impact on the environment.

USP Class VI and ISO 10993-5, 6, 10 and 11 guidelines

Natural and Antistatic PTFE Hose Liners, Platinum Cured Silicone Rubber Covers (White and Clear) and EPDM Rubber Cover (Blue) have been independently tested in accordance with USP protocols and are found to conform to the requirements of USP Class VI Chapter <88>.

Natural and Antistatic PTFE Hose Liners now also meet the more stringent USP Class VI and ISO 10993-6,10 and 11 guidelines at 121°C (250°F) with a "no reaction" classification.

Natural and Antistatic PTFE Hose Liners and Platinum Cured Silicone Rubber Covers (White and Clear) have also been tested in accordance with USP protocols and are found to conform to the requirements of USP Class VI <87>, the L929 MEM Elution Test and are considered non-cytotoxic.

Natural and Antistatic PTFE Hose Liners have now been further tested and have passed the more stringent USP Class VI and ISO 10993-5 guidelines at 121°C (250°F).

USP <661> Physicochemical Test for Plastics

Natural and Antistatic (Carbon filled) Externally Convoluted Smoothbore PTFE hose has been tested in accordance with USP Physicochemical Test for Plastics and found to meet the criteria of the following reference: USP34, NF 29, 2011. Monograph <661> Containers, Physicochemical Test-Plastics.

FDA

The Materials used to manufacture the natural PTFE Tube liner conforms to FDA 21 CFR 177.1550, and the antistatic PTFE liner conforms to FDA 21 CFR 178.3297.

BPSA leachables and extractables testing

Aflex Hose Natural and Antistatic PTFE Hose Liner Tube has been independently tested in accordance with BPSA recommendations, and found to be satisfactory.

Copies of the Test Report are available for specific assessments to be made.

Flame Resistant

To special order only, Aflex Hose are able to supply hose with a special rubber cover which is compliant with the requirements of EN 45545, DIN 5510 and NFF 16101 specifications.

Pharmaceutical and Chemical Manufacturers Approvals

Most of the major pharmaceutical and Chemical manufacturing companies in the world have audited and/or approved Aflex Hose as a Hose Supplier.

CE Marking (Europe only)

Aflex has been assessed by The British Standards Institution (BSI) and found to comply with the Pressure Equipment Directive 2014/68/EU Conformity Assessment Module D1, approved to CE Mark applicable hose products, accompanied by a Hose Usage Data Sheet, and a Declaration of Conformity.

Attestations of Conformity to ATEX Directive 2014/34/EU (Potentially Explosive Atmospheres)

Available for hose assemblies for components used in Gas Zones 1 & 2 and Dust Zones 21 & 22, when applicable.

Material Certification to EN10204

Available for all the hose or hose assembly components.

Certificates of Conformity to BS EN ISO/IEC 17050

Are available for all products.

Hose Testing

Each assembly is pressure tested to 2.0 times maximum working pressure before despatch, and pressure test certificates can be supplied.

Fire Resistance to BS5173 Section 103.13 Part 6.2 and 6.3

RC Grade Corroline⁺ hose assemblies are "Fire Resistant". If DBK-300 is added at both ends, the assemblies are upgraded to "Fire Proof".

Food Contact

Manufactured in compliance with **Regulation (EC) No 1935/2004** - on materials and articles intended to come in to contact with food,

Commission regulation (EU) No 10/2011 - relating to plastic materials and articles intended to come into contact with food and

Regulation (EC) No 2023/2006 - on good manufacturing practise for materials and articles intended to come in to contact with food.

Hose Configuration & Length Calculations - for Bend Radius

Hose Configuration Requirements

Hose Assemblies are usually connected at both ends in service. They may then either remain in a fixed, or static configuration or in a flexing, or dynamic configuration.

Whether static or dynamic, the First Rule concerning the configuration of the hose is that the bend radius of the hose must never be less than the Minimum Bend Radius (MBR) for the hose as listed in the relevant hose brochure.

The most common situation when this is likely to occur is when the hose is flexed at the end fitting, with stress being applied to the hose at an angle to the axis of the end fitting. Typically, this happens either because the length of the hose is too short, or because the weight of the hose plus contents creates a stress at an angle to the end fitting.

The Second Rule, therefore, if possible, is to design the configuration to ensure that any flexing in the hose takes place away from the end fittings.

(Dynamic) Configuration

INCORRECT - Hose too short

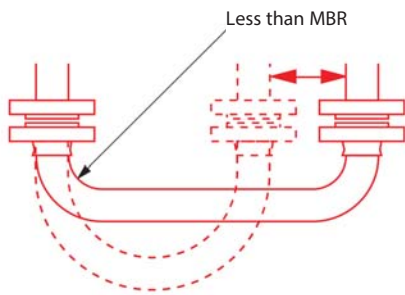

CORRECT - No flex at End Fittings

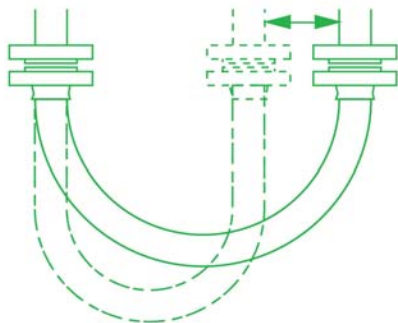

(Static) Configuration

INCORRECT - Weight of hose is at 90° to Axis of End Fittings

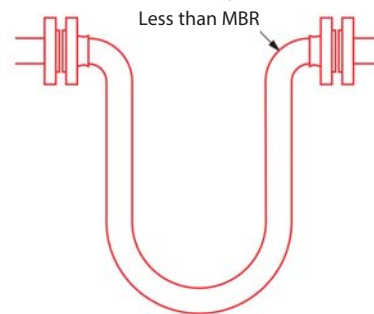

CORRECT - No flex at end fittings

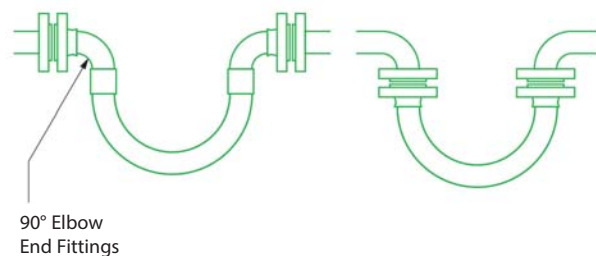

Hose Configuration & Length Calculations - for Abrasion & Torque

The Third Rule is that the hose configuration should always be designed, and supported where necessary, to avoid any possibility of external abrasion. In some cases, the length, configuration and angle of the hose can be designed to avoid abrasion. In others, static or moving support frames or support wheels are required.

INCORRECT - Abrasion against hose

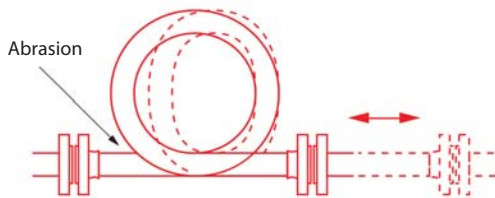

INCORRECT - Abrasion inside support

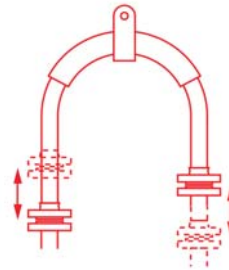

CORRECT - No hose abrasion

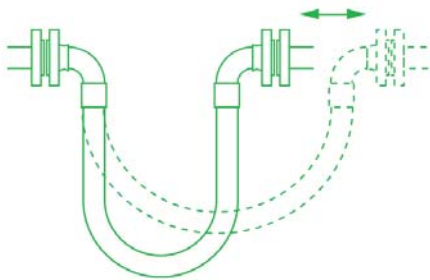

CORRECT - No abrasion over support

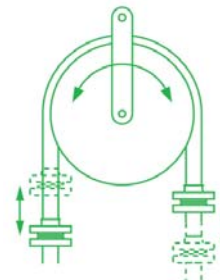

The Fourth Rule is that the hose must not be subjected to torque, either during connection, or as a result of the flexing cycle.

Torque (twist) in the hose can be applied during connection if the hose is accidentally twisted, or if the second end being connected is a screwed connection, and the hose is subjected to torque during final tightening.

In a flexing application, if any flexing cycle of the hose occurs in 3 dimensions instead of 2, then torque will also occur:

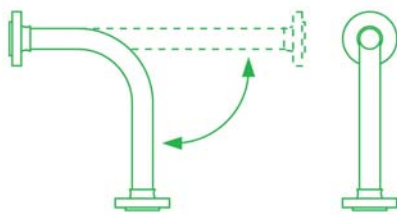

CORRECT - Flexing movement takes place in 2 dimensions

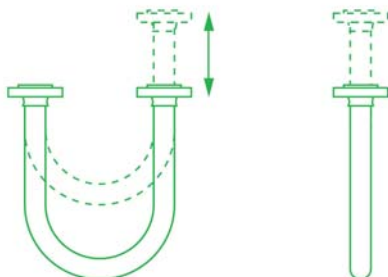

INCORRECT - Flexing movement takes place in 3 dimensions so torque is applied

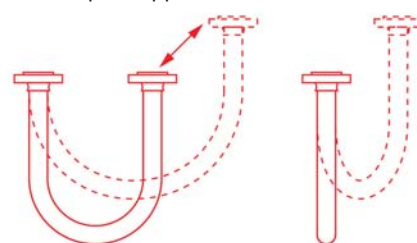

Hose Configuration - for Length Calculation

Calculating the Hose Length

The formula for calculating the bent section of the hose length around a radius is derived from the basic formula that the circumference of a circle = $2\pi R$, where R = the radius of the circle, and π = a constant, = 3.142.

So, if the hose goes around a 90° bend, which is $\frac{1}{4}$ of a full circumference, and the radius of the bend is R , then the length of the hose around the bend is = $\frac{1}{4} \times 2\pi R$. Or half way round, in a U-shape, = $\frac{1}{2} \times 2\pi R$.

Note :

In calculating the length of a hose assembly, the (non-flexible) length of the end fittings must be added in, also the length of any straight sections of hose, as in the following example:

Example :

To calculate the length for a 2" bore size hose with flange end fittings, to be fitted in a 90° configuration with one leg 400mm long, the other 600mm long.

$$\begin{aligned} \text{Length of Bent Section (yellow)} &= \frac{1}{4} \times 2\pi R \text{ (334)} \\ &= \frac{1}{4} \times 2 \times 3.142 \times 334 = 525\text{mm} \end{aligned}$$

$$\begin{aligned} \text{Length of top, Straight Section, including the top end fitting length} \\ &= 600 - 334 = 266\text{mm} \end{aligned}$$

$$\text{Length of bottom end fitting} = 66\text{mm}$$

$$\text{Total length of Hose Assembly} = 525 + 266 + 66 = 857\text{mm}$$

Things to consider

- A hose will normally take the longest radius available to it to go around a corner, not the MBR! Also - always remember to include the non-flexible end fitting lengths.
- In dynamic applications, remember to always calculate the lengths for the most extended configuration during the flexing cycle, not the least extended.
- If the configuration is simply too complex for calculation, then obtain a length of flexible tubing of some kind, mark on paper, or a wall, or floor, or both where the connection points will be relative to each other, scaled down if necessary, then manually run the flexible tubing between them with full radii round bends. Measure the extended length, then scale up if necessary to determine the approximate length of the hose.

If in doubt, consult Aflex Hose.

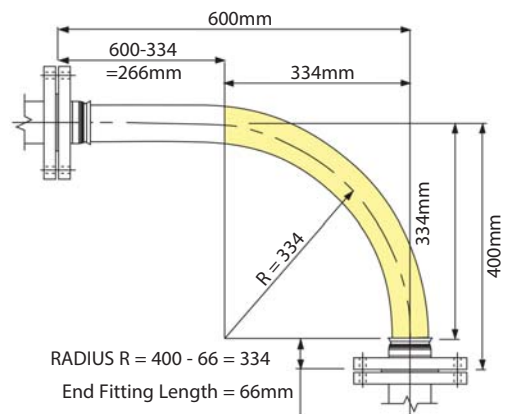
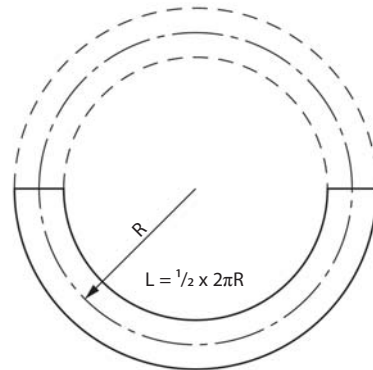
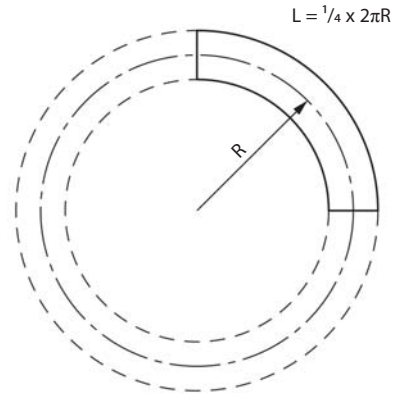

Conditions of Sale

DEFINITIONS

- (1) "Afex Hose" shall mean Afex Hose USA, LLC.
- (2) "Afex Hose Products" shall mean those products which are manufactured by Afex Hose USA, LLC and are described on the Afex Hose website.
- (3) "Factored Products" shall mean products which are supplied by Afex Hose, but are not manufactured by Afex Hose Ltd, and are purchased by Afex Hose from another supplier or manufacturer.
- (4) "Customer" shall mean the individual or entity that is purchasing Afex Hose Products hereunder.
- (5) "Full Product Brochure" shall mean the brochure for each specific product available at <http://www.afex-hose.com/products-and-markets>.

GENERAL

- (6) These Conditions of Sale form the basis of the contract of sale between Afex Hose and the Customer. In the event of any conflict between the terms and conditions set forth in these Conditions of Sale and any other Customer document, these Conditions of Sale shall govern, unless otherwise agreed to in writing and authorized and signed for by a Director or General Manager of Afex Hose.
- (7) Unless otherwise agreed to in writing, delivery will be [F.O.B.] Afex Hose's facilities in Pipersville, Pennsylvania. Title and all risks of loss or damage pass to the Customer upon delivery to the Customer or third party carrier. Ship dates specified by Afex Hose are only Afex Hose's best estimates and Afex Hose's only responsibility will be to use reasonable commercial efforts to meet all specified delivery dates.

CUSTOMER RESPONSIBILITIES AND OBLIGATIONS

- (8) It is the Customer's strict responsibility to review all of the usage conditions and usage limitations given for the Afex Hose Products which are intended for use in a particular application, to ensure that the application conditions are in compliance with those usage limitations. The usage conditions and limitations are referred to in these Conditions of Sale, and are further specified in the relevant Full Product Brochure. The Customer shall consult the latest, up to date hose product information and Full Product Brochure at the time of ordering, which are only available and downloadable from the Afex Hose website at <http://www.afex-hose.com/products/>, or on request from Afex Hose. The Customer here represents and warrants that it has read and understands the applicable Full Product Brochure and the usage conditions and the usage limitations set forth therein, and has ensured their compliance with the application conditions.
- (9) If the Customer sells or assigns any Afex Hose Products to any other person or entity, the Customer shall ensure that the final end user of the Afex Hose Products is supplied with these Conditions of Sale, the applicable Full Product Brochures, the Afex Hose website address, together with notification of the requirement to review the usage conditions and limitations. The Customer shall include the terms and conditions set forth herein in its Conditions of Sale to any third party. The Customer hereby agrees and acknowledges that Afex Hose shall have no liability whatsoever for claims arising in whole or in part out of the Customer selling or assigning the Afex Hose Products to a third party that does not use the Afex Hose Products in accordance with Afex Hose's usage requirements and limitations ("Non-Conforming Use Claims"). The Customer shall indemnify and hold harmless Afex Hose, its officers, directors, employees, affiliates and representatives for any and all claims, damages, penalties and losses arising out of or related to Non-Conforming Use Claims.
- (10) The Customer agrees and acknowledges that for any intended hose application in which special conditions apply which are not defined, or not defined sufficiently in the Product Brochure, the Customer shall write to Afex Hose requesting written advice relating to any usage limitations resulting from special conditions. The Customer shall ensure the design suitability and safety of the Afex Hose Products in their intended applications, giving particular consideration to any special condition relating to, but not restricted to the chemical and electrostatic compatibility of the fluids or gases passing through, the possibility of diffusion of fluid or gases through the PTFE hose lining, the possibility of external corrosive conditions, the types and likelihood of excessive mechanical abuse, such as abrasion (internal or external), crushing, excessive flexing or vibrations, etc. and any excessive temperature and/or pressure "pulsing" conditions, or any other condition which may cause premature hose failure. The Customer shall consider, and take account of the degree of risk involved in any hose failure, including the provision of adequate protection in the event of any risk to any persons. In applications where any type of hose failure would lead to financial losses if the hose is not replaced immediately, the Customer agrees and acknowledges that it shall be the Customer's responsibility to order and

hold in stock spare hose(s) accordingly. The Customer shall advise Afex Hose in writing at the time of placing the enquiry and on any purchase order if there are any special requirements for the hose, including special cleaning, or drying, or extra testing requirements which are in addition to normal industrial standards. The Customer agrees and acknowledges that Afex Hose, its officers, directors, employees, affiliates and representatives shall not be held liable for any claims or obligations arising out of the Customer's failure to fulfill any or all of its responsibilities set forth in this Section 9.

FACTORED PRODUCTS

- (11) The Customer accepts that Afex Hose are not expert in the technical features which apply to Factored Products and their use in application. Afex Hose will pass on to the Customer all the written information which they have regarding the Factored Product, but the Customer shall be responsible for ensuring that this and any other necessary Factored Product information is obtained and is reviewed which is sufficient to ensure that the Factored Product is fit for purpose in the intended usage application. If any application requirements apply which are not fully covered by the information which the Customer can obtain, then the Customer undertakes not to use or supply the Factored Product for use in that application. The Customer is also responsible for ensuring that the Factored Product will not be subjected to levels of usual or accidental physical abuse in service which would cause the Factored Product to fail. The Customer agrees and acknowledges that Afex Hose, its officers, directors, employees, affiliates and representatives shall not be held liable for any claims or obligations arising out of the Customer's failure to fulfill any or all of its responsibilities set forth in this Section 11.
- (12) If the Customer has any doubts concerning these or any other usage conditions and limitation or safety parameters, the Customer shall consult Afex Hose at the number and address in the Notice Provisions below and request a written response to any queries.

HOSE SERVICE LIFE; 24 MONTH WARRANTY

- (13) It is not possible to guarantee a minimum service life for any of the Afex Hose Products or Factored Products which can be applicable for every type of application. As such, Customer acknowledges that, except as provided below in Sections 14, 15 and 16 Afex Hose is not guaranteeing a minimum service life of any of the Afex Hose Products.
- (14) Service life predictions or guarantees can only be given in cases where all the relevant information concerning the application is given in writing to Afex Hose, and Afex Hose subsequently replies in writing with the service life prediction prior to the order being placed.
- (15) If such a written undertaking is not sought and given, Afex Hose shall not be held liable for any Afex Hose Product or Factored Products failure which the Customer considers to be premature, excepting failures which are due to faulty materials or manufacturing defects which occur within 24 months or 12 months, as applicable, of supply as provided in Section 16 below.
- (16) Afex Hose warrants its Afex Hose Products to be free from faulty materials or manufacturing defects from the date of the delivery, for 24 months; provided, however, that all Hose Assemblies which are "ETH" (Electrical Trace Heated) Grade or are Factored Products are only warranted for 12 months.
- (17) AFEX HOSE MAKES NO WARRANTY OF ANY KIND WHATSOEVER, EXPRESS OR IMPLIED OTHER THAN AS SPECIFICALLY STATED HEREIN, AND THERE ARE NO WARRANTIES OF MERCHANTABILITY AND/OR FITNESS FOR A PARTICULAR PURPOSE WHICH EXCEED THE OBLIGATIONS AND WARRANTIES SPECIFICALLY STATED HEREIN.

PRODUCT FAILURE

- (18) In the event of an Afex Hose product failure during the applicable warranty period set forth in Section 16, the Customer shall provide Afex Hose with written notification within forty-eight (48) hours of discovering the fault. Afex Hose requires that the Afex Hose Products not be cut up or tampered with, but should be decontaminated and returned to Afex Hose, plus a decontamination certificate, for examination and analysis of the fault. The Customer should also provide full details in writing of the application conditions under which the hose failed, including Pressure, Vacuum, Temperature, Flexing and any cycling of any of these, also the fluids, gases and any cleaning products passed through the hose, and the total time that the hose has been in service also the original order number and the Serial Number for the hose. The Customer may send its own witness to the examination if required. Afex Hose will provide a Non-Conformance Report to the Customer. The Customer shall bear the cost of returning the Afex Hose Products that have failed; provided, however, as set forth in Section 20 below, Afex Hose shall reimburse the Customer for any shipping costs if it is determined that the failure is covered by the warranty set forth in Section 16.

Conditions of Sale continued

(19) In the event of a Factored Product failure, the Customer shall advise Aflex Hose with written notification within 48 hours of discovering the fault. The failed product shall not be tampered with or de-constructed in any way, but shall be decontaminated as required to render it fully safe and free from harmful substances and held awaiting advice concerning its disposition from Aflex Hose. Full details concerning the application, the time in use in the application and a full description of the type of failure shall be supplied to Aflex Hose, who shall pass this information on to the supplier or manufacturer of the Factored Product for advice concerning the appropriate course of action. The Customer will then be advised as to the disposition of the failed product.

(20) If Aflex Hose determines that the faulty materials or a manufacturing defect in the Aflex Hose Product or Factored Product is responsible for the hose failure, the maximum liability shall be the invoice value of the failed hose itself, or the invoice value of the whole customer order as determined by Aflex Hose in its sole discretion, along with any reasonable costs for removal and replacement of the hose, and costs for packing and despatching the failed hose back to Aflex Hose.

UNTESTED HOSE FOR SELF ASSEMBLY BY CUSTOMERS

(21) Aflex Hose sometimes supplies "loose" hose, without end fittings attached to a Self Assembly Customer, who will then cut the hose to length and attach end fittings to make up Hose Assemblies for their own use, or for sale to their own customers.

(22) Unless the Customer requests, and Aflex Hose confirms that the 'loose' hose is pressure tested before supply, such testing is not normally applied by Aflex Hose, because this testing requirement is otherwise satisfied by the Self Assembly Customer during his own testing of the finished Hose Assemblies made up using the "loose" hose. Self Assembly Customers agree and acknowledge that they are solely responsible for carrying out hydrostatic pressure testing of 100% of such assemblies to 2.0 times the Maximum Working Pressure (MWP) of the hose assembly as specified in the relevant Full Product Brochure before supply for end use, to validate both the hose and the end fitting attachment.

(23) When pressure testing braided hoses with a plastic or rubber outer cover, the cover will mask any signs of leakage for a time. The Customer agrees and acknowledges that after the hydrostatic pressure test, it is required to test each covered hose assembly with an internal helium gas pressure of 30 Bar (450 psi) for hose sizes up to 1" and 15 Bar (225 psi) for hose sizes above 1", with the hose assembly immersed in water to enable leak detection by gas bubbles, for a minimum test period of 5 minutes.

(24) The "Self Assembly" Customer agrees and acknowledges that it shall determine and approve the Design Suitability of the hose assemblies for their intended use before supply and that, except as set forth in Section 22, it shall indemnify and hold Aflex Hose harmless from any Claims and Losses arising from Design Suitability for a Self Assembly Customer. This includes proceeding in accordance with Section (8) and Section (9) above.

(25) Aflex Hose's liability is limited to Aflex Hose Products which are assembled by approved Self Assembly Customers if all the hose and fitting components were supplied by Aflex Hose or approved for use by Aflex Hose in writing, and they were assembled and tested in accordance with Aflex Hose's current Manufacturing and Testing Instructions, available to approved Self Assemblers in an I-Bay on the Aflex Hose website.

UNTESTED HOSE ASSEMBLIES

(26) Aflex Hose is sometimes requested by Customers to attach non-standard end fittings to hose assemblies which they, supply, and in some cases it is not possible to connect these fittings to the Aflex Hose pressure test system. In such cases a "concession not to test" is obtained from the Customer, and a label is attached to the hose assembly, warning that it requires pressure testing before use. The Customer agrees and acknowledges that Aflex Hose shall have no liability whatsoever if the Customer does not comply with the warning that requires pressure testing before use.

FORCE MAJEURE

(27) Aflex Hose shall not be liable for any delay in delivery, failure to deliver or default in performing in accordance with any Customer's order if the delay or default is due to: (a) fires, floods, strikes, or other labor disputes, accidents to Aflex Hose's production facilities, acts of sabotage, riots, natural disasters, difficulties procuring materials, shortages of raw materials, interference by civil or military authorities, whether legal or de facto, governmental restrictions, including but not limited to failure to obtain export licenses, delays in transportation or lack of transportation facilities, restrictions imposed by federal, state or other governmental legislation or, rules or

regulations thereof, including a force majeure event occurring in respect to one of Aflex Hose's suppliers; or (b) any other cause beyond Aflex Hose's control.

GOVERNING LAW; JURISDICTION

(28) These Conditions of Sale and all rights, duties and obligations hereunder, including any and all other Customer agreements and orders shall be governed by Pennsylvania law without regard to its conflicts of laws principles.

(29) The Customer acknowledges and agrees that any disputes arising out of or related in any way to this Agreement, including a breach of this Agreement, shall be brought exclusively in the state courts located in [Bucks County], Pennsylvania or in the Federal District Court located in the Eastern District of Pennsylvania. Furthermore, Customer knowingly, voluntarily and irrevocably (a) consents to the exclusive jurisdiction of these courts, (b) waives any immunity or objection, including any objection to personal jurisdiction or the laying of venue or based on the grounds of forum non conveniens, which it may have from or to the bringing of the dispute in such jurisdiction, (c) waives any personal service of any summons, complaint or other process that may be made by any other means permitted by the Commonwealth of Pennsylvania, (d) waives any right to trial by jury, (e) agrees that any such dispute will be decided by court trial without a jury, (f) understands that it is giving up valuable legal rights under this Section 29, including the right to trial by jury, and that it voluntarily and knowingly waives those rights.

LIMITATIONS OF LIABILITY

(30) Aflex Hose Products and Factored Products have not been designed or tested for use in aerospace, medical implantation or radioactive applications, and such use is therefore strictly prohibited unless written approval from Aflex Hose has been given. Customer agrees and acknowledges that it is aware of the limitations set forth in this Section 30 and hereby agrees that Aflex Hose shall not have any liability whatsoever in the event Customer uses Aflex Hose Products and Factored Products for aerospace, medical implantation or radioactive applications. Customer agrees to indemnify Aflex Hose, its officers, directors, employees, affiliates and representatives for any and all Claims and Losses arising out of Customer's use of the Aflex Hose Products for aerospace, medical implantation or radioactive applications.

(31) Aflex Hose will not accept liability for any failures of the Aflex Hose Products and Factored Products which are caused by Customers failing to perform their Responsibilities as specified in these Conditions of Sale.

(32) NOTWITHSTANDING ANYTHING TO THE CONTRARY HEREIN, IN NO EVENT SHALL AFLEX HOSE BE LIABLE FOR ANY SPECIAL, INDIRECT, INCIDENTAL, CONSEQUENTIAL, EXEMPLARY, OR PUNITIVE DAMAGES, LOSS OF PROFITS OR REVENUE, LOSS OF PROCESS PRODUCTS, DAMAGE TO EQUIPMENT, DOWNTIME COSTS, OR LOSS OF USE EVEN IF INFORMED OF THE POSSIBILITY OF SUCH DAMAGES. TO THE EXTENT PERMITTED BY APPLICABLE LAW, THESE EXCLUSIONS AND LIMITATIONS WILL APPLY REGARDLESS OF WHETHER LIABILITY ARISES FROM FAILURE OF THE PRODUCT(S), BREACH OF CONTRACT, FAILURE TO DELIVER ON TIME, WARRANTY, TORT (INCLUDING, BUT NOT LIMITED TO, NEGLIGENCE), BY OPERATION OF LAW, OR OTHERWISE.

COMPLETION OF BULK HOSE ORDERS

(33) Due to the nature of the production of PTFE hose, Aflex Hose reserves the right to call an order complete in the following situations. If a product is a standard Aflex product (as listed in Aflex product brochures) a figure of +10% of original order quantity can be supplied. If the product is a non-standard product and outside the Aflex standard product range the figure of +/- 10% of the original order quantity can be supplied. Goods supplied within these parameters would render the order complete.

NOTICE PROVISIONS

(34) Any written notice required to be provided to Aflex Hose shall be sent to the following address: 6111 Keller's Church Road, Unit B, Pipersville, Pennsylvania, PA18947.

EXCLUSION OF CISG

(35) The United Nations Convention on Contracts for the International Sale of Goods shall not apply to these Conditions of Sale and any and all other Customer documents.



BIOFLEX ULTRA
CORROFLON
CORROLINE+
PHARMALINE N&X
SMOOTHBORE
HYPERLINE FX
VISIFLON

UK

Spring Bank Industrial Estate
Watson Mill Lane
Sowerby Bridge
Halifax
West Yorkshire, HX6 3BW
Tel: +44 (0) 1422 317200
Fax: +44 (0) 1422 836000

USA

32 Appletree Lane
Pipersville
Bucks County
Pa 18947
Tel: 215 - 766 - 1455
Fax: 215 - 766 - 1688



WWW.AFLEX-HOSE.COM

